



## ***Refrigerated Pizza Prep Units***

Models PT-CN-1270-HC, 1829-HC, 2337-HC

Items 50042, 50043, 50044

## ***Instruction Manual***

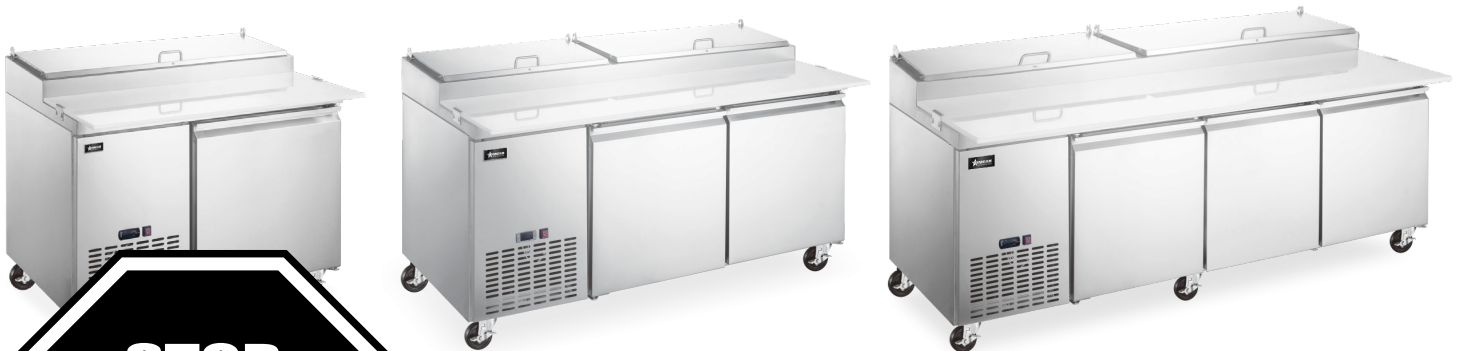

*Revised - 11/11/2024*



Toll Free: 1-800-465-0234  
Fax: 905-607-0234  
Email: [service@omcan.com](mailto:service@omcan.com)  
[www.omcan.com](http://www.omcan.com)



# ***Table of Contents***

Model PT-CN-1270-HC / Model PT-CN-1829-HC / Model PT-CN-2337-HC

---

<b>Section</b>	<b>Page</b>
Disclaimer -----	3
General Information -----	4 - 5
Safety and Warranty -----	5 - 7
Technical Specifications -----	7
Installation -----	8 - 9
Maintenance -----	10
Troubleshooting -----	10 - 12
Controller Instructions -----	12 - 14
Parts Breakdown -----	15 - 20
Electrical Schematics -----	21 - 23
Notes -----	24 - 26
Warranty Registration -----	27

*OMCAN IS NOT RESPONSIBLE FOR ANY DAMAGES DUE TO WATER LEAKS. WARRANTY FOR WATER LEAKS IS VOID IF THE AMBIENT ROOM TEMPERATURE EXCEEDS 75°F AND 55% RELATIVE HUMIDITY, AND THE APPLIANCE DRAIN IS NOT CONNECTED DIRECTLY TO A FLOOR DRAIN.*

---

*OMCAN N'EST PAS RESPONSABLE DES DOMMAGES DUS AUX FUITES D'EAU. LA GARANTIE POUR LES FUITES D'EAU EST ANNULÉE SI LA TEMPÉRATURE AMBIANTE DE LA PIÈCE DÉPASSE 75°F ET 55% D'HUMIDITÉ RELATIVE, ET SI LE DRAIN DE L'APPAREIL N'EST PAS RACCORDÉ DIRECTEMENT À UN DRAIN DE PLANCHER.*

---

*OMCAN NO SE HACE RESPONSABLE DE LOS DAÑOS CAUSADOS POR FUGAS DE AGUA. LA GARANTÍA POR FUGAS DE AGUA QUEDA ANULADA SI LA TEMPERATURA AMBIENTE SUPERA LOS 75°F Y EL 55% DE HUMEDAD RELATIVA, Y EL DESAGÜE DEL APARATO NO ESTÁ CONECTADO DIRECTAMENTE A UN DESAGÜE DE PISO.*

## ***General Information***

---

**Omcan Manufacturing and Distributing Company Inc., Food Machinery of America, Inc. dba Omcan and Omcan Inc. are not responsible for any harm or injury caused due to any person's improper or negligent use of this equipment. The product shall only be operated by someone over the age of 18, of sound mind, and not under the influence of any drugs or alcohol, who has been trained in the correct operation of this machine, and is wearing authorized, proper safety clothing. Any modification to the machine voids any warranty, and may cause harm to individuals using the machine or in the vicinity of the machine while in operation.**

### **CHECK PACKAGE UPON ARRIVAL**

Upon receipt of an Omcan shipment please inspect for external damage. If no damage is evident on the external packaging, open carton to ensure all ordered items are within the box, and there is no concealed damage to the machine. If the package has suffered rough handling, bumps or damage (visible or concealed), please note it on the bill of lading before accepting the delivery and contact Omcan within 24 hours, so we may initiate a claim with the carrier. A detailed report on the extent of the damage caused to the machine must be filled out within three days, from the delivery date shown in the shipping documents. Omcan has no recourse for damaged products that were shipped collect or third party.

**Before operating any equipment, always read and familiarize yourself with all operation and safety instructions.**

**Omcan would like to thank you for purchasing this machine. It's of the utmost importance to save these instructions for future reference. Also save the original box and packaging for shipping the equipment if servicing or returning of the machine is required.**

---

**Omcan Fabrication et distribution Compagnie Limitée et Food Machinery d'Amérique, dba Omcan et Omcan Inc. ne sont pas responsables de tout dommage ou blessure causé du fait que toute personne ait utilisé cet équipement de façon irrégulière. Le produit ne doit être exploité que par quelqu'un de plus de 18 ans, sain d'esprit, et pas sous l'influence d'une drogue ou d'alcool, qui a été formé pour utiliser cette machine correctement, et est vêtu de vêtements de sécurité appropriés. Toute modification de la machine annule toute garantie, et peut causer un préjudice à des personnes utilisant la machine ou des personnes à proximité de la machine pendant son fonctionnement.**

### **VÉRIFIEZ LE COLIS DÈS RÉCEPTION**

Dès réception d'une expédition d'Omcan veuillez inspecter pour dommages externes. Si aucun dommage n'est visible sur l'emballage externe, ouvrez le carton afin de s'assurer que tous les éléments commandés sont dans la boîte, et il n'y a aucun dommage dissimulé à la machine. Si le colis n'a subi aucune mauvaises manipulations, de bosses ou de dommages (visible ou cachée), notez-le sur le bond de livraison avant d'accepter la livraison et contactez Omcan dans les 24 heures qui suivent, pour que nous puissions engager une réclamation auprès du transporteur. Un rapport détaillé sur l'étendue des dommages causés à la machine doit être rempli dans un délai de trois jours, à compter de la date de livraison indiquée dans les documents d'expédition. Omcan n'a aucun droit de recours pour les produits endommagés qui ont été expédiés ou cueillis par un tiers transporteur.

**Avant d'utiliser n'importe quel équipement, toujours lire et vous familiariser avec toutes les opérations et les**



## **General Information**

---

consignes de sécurité.

Omcan voudrais vous remercier d'avoir choisi cette machine. Il est primordial de conserver ces instructions pour une référence ultérieure. Également conservez la boîte originale et l'emballage pour l'expédition de l'équipement si l'entretien ou le retour de la machine est nécessaire.

---

Omcan Empresa De Fabricacion Y Distribucion Inc. Y Maquinaria De Alimentos De America, Inc. dba Omcan y Omcan Inc. no son responsables de ningun daño o perjuicio causado por cualquier persona inadecuada o el uso descuidado de este equipo. El producto solo podra ser operado por una persona mayor de 18 años, en su sano juicio y no bajo alguna influencia de droga o alcohol, y que este ha sido entrenado en el correcto funcionamiento de esta máquina, y ésta usando ropa apropiada y autorizada. Cualquier modificación a la máquina anula la garantía y puede causar daños a las personas usando la máquina mientras esta en el funcionamiento.

### **REVISE EL PAQUETE A SU LLEGADA**

Tras la recepcion de un envio Omcan favor inspeccionar daños externos. Si no hay daños evidentes en el empaque exterior, Habra el carton para asegurarse que todos los articulos solicitados estén dentro de la caja y no encuentre daños ocultos en la máquina. Si el paquete ha sufrido un manejo de poco cuidado, golpes o daños (visible o oculto) por favor anote en la factura antes de aceptar la entrega y contacte Omcan dentro de las 24 horas, de modo que podamos iniciar una reclamación con la compañía. Un informe detallado sobre los daños causados a la máquina debe ser llenado en el plazo de tres días, desde la fecha de entrega que se muestra en los documentos de envío. Omcan no tiene ningun recurso por productos dañados que se enviaron a recoger por terceros.

**Antes de utilizar cualquier equipo, siempre lea y familiarizarse con todas las instrucciones de funcionamiento y seguridad.**

Omcan le gustaría darle las gracias por la compra de esta máquina. Es de la mayor importancia para salvar estas instrucciones para futuras consultas. Además, guarda la caja original y el embalaje para el envío del equipo si servicio técnico o devolución de la máquina que se requiere.

## **Safety and Warranty**

---

Please pay close attention to the safety notices in this section. Disregarding these notices may lead to serious injury and/or damage to the unit.

### **ATTENTION**

- To minimize shock and fire hazards, be sure not to overload outlet. Please designate one outlet for your unit.
- Do not use extension cords.

# ***Safety and Warranty***

---

- Do not put your hands under the unit when the unit is required to be moved.
- When the unit is not in use for a long period of time, please unplug the unit from the outlet.
- After unplugging the unit, wait at least 10 minutes before re-plugging it. Failure to do so could cause damage to the compressor.

## **UNPLUG CORD**

- To minimize shock and fire hazards, please do not plug or unplug the cord with wet hands.
- During maintenance and cleaning, please unplug the unit.

## **PROPER GROUNDING REQUIRED**

- To minimize shock and fire hazards, make sure that the unit is properly grounded.

## **PROHIBITION**

- Do not attempt to remove or repair any component unless instructed by factory.
- Make sure that the unit is not resting on or against the electrical cord and plug.
- To minimize personal injury, do not hang on the doors.
- Do not store any flammable and explosive gas or liquids inside the unit.
- Do not attempt to alter or tamper with the electrical cord.

**RESIDENTIAL USERS: vendor assumes no liability for parts or labor coverage for component failure or other damages resulting from installation in non-commercial or residential applications. The right is reserved to deny shipment for residential usage; if this occurs, you will be notified as soon as possible.**

## **2 YEARS PARTS AND LABOUR / 5 YEARS PARTS ONLY ON COMPRESSOR WARRANTY**

**Within the warranty period, contact Omcan Inc. at 1-800-465-0234 to schedule an Omcan authorized service technician to repair the equipment locally.**

**Unauthorized maintenance will void the warranty. Warranty covers electrical and part failures, not improper use.**

**Please see <https://omcan.com/disclaimer> for complete info.**

## **WARNING:**

The packaging components are classified as normal solid urban waste and can therefore be disposed of without difficulty.

**In any case, for suitable recycling, we suggest disposing of the products separately (differentiated waste) according to the current norms.**

## *Safety and Warranty*

**DO NOT DISCARD ANY PACKAGING MATERIALS IN THE ENVIRONMENT!**

## *Technical Specifications*

<b>Model</b>	<b>PT-CN-1270-HC</b>	<b>PT-CN-1829-HC</b>	<b>PT-CN-2337-HC</b>
<b>Item Number</b>	<b>50042</b>	<b>50043</b>	<b>50044</b>
<b>Temperature Range</b>	0.6 - 5°C / 33 - 41°F		
<b>Max Ambient Temp Rating</b>	24°C / 75°F		
<b>Horsepower</b>	1/6 HP	1/5 HP	1/4+ HP
<b>Electrical</b>	110-120V / 60Hz / 1		
<b>Current</b>	2.64A	3.42A	5.28A
<b>Refrigerant</b>	R290		
<b>Isolation Material</b>	Cyclopentane		
<b>Cooling System</b>	Ventilated		
<b>Number of Inserts</b>	6 - 1/3 pans	9 - 1/3 pans	12 - 1/3 pans
<b>Number of Doors</b>	1	2	3
<b>Number of Shelves</b>	1	2	3
<b>Shelf Capacity</b>	72.8 lbs. / 33 kgs.	63.9 lbs. / 29 kgs.	61.7 lbs. / 28 kgs.
<b>Cutting Board</b>	49.8" x 19.5" x 0.6" 1264 x 496 x 15mm	70.8" x 19.5" x 0.6" 1798 x 496 x 15mm	91.8" x 19.5" x 0.6" 2332 x 496 x 15mm
<b>Exterior Dimensions</b>	49.8" x 31.5" x 42.8" 1266 x 800 x 1088mm	70.9" x 31.5" x 42.8" 1800 x 800 x 1088mm	91.9" x 31.5" x 42.8" 2334 x 800 x 1088mm
<b>Interior Dimensions</b>	27.4" x 22.8" x 26.2" 696 x 580 x 665mm	48.4" x 22.8" x 26.2" 1230 x 580 x 665mm	69.4" x 22.8" x 26.2" 1764 x 580 x 665mm
<b>Packaging Dimensions</b>	54.3" x 36.2" x 45.7" 1380 x 920 x 1160mm	75.6" x 36.2" x 45.7" 1920 x 920 x 1160mm	96.5" x 36.2" x 45.7" 2450 x 920 x 1160mm
<b>Net Volume</b>	391 L / 13.8 cu.ft.	477 L / 16.84 cu.ft.	684 L / 24.15 cu.ft.
<b>Weight</b>	374.8 lbs. / 170 kgs.	432.1 lbs. / 196 kgs.	566.6 lbs. / 257 kgs.
<b>Packaging Weight</b>	498.2 lbs. / 226 kgs.	564.4 lbs. / 256 kgs.	720.9 lbs. / 327 kgs.

# Installation

---

## IMPORTANT!!!PLEASE READ BEFORE INSTALLATION

- If the unit has recently been transported. Please let unit stand still for a minimum of 24 hours before plugging it in.
- Make sure that the unit drops down to desired temperature before loading the unit with product.
- Make sure that there is proper ventilation around the unit in the area where it will operate.
- Make sure all accessories are installed (i.e. shelves, shelf clips, casters) before plugging the unit in.
- Please read through the Operation / Owner's Manual in its entirety.

## CABINET LOCATION GUIDELINES

- Install the unit on strong and leveled surfaces.
  - Unit may make unpleasant noises if surface is uneven.
  - Unit may malfunction if surface is uneven.
- Install the unit in an indoor, well-ventilated area.
  - Unit performs more efficiently in a well-ventilated area.
  - For best performance, please maintain clearance of 6" on the back of the unit.
  - Outdoor use may cause decreased efficiency and damage to the unit.
- Avoid installation in a high humidity and/or dusty area.
  - Humidity could cause unit to rust and decrease efficiency of the unit.
  - Dust collected on condenser coil will cause unit to malfunction. Clean the condenser at least once a month with a brush or clean cloth.
  - Malfunction due to dirty condenser will void warranty.
- Select a location away from heat and moisture-generating equipment.
  - High ambient temperature will cause the compressor to overwork, leading to higher energy bills and gradual breakdown of the unit.
  - Malfunction due to high ambient temperature will void warranty.

## ELECTRICAL

Please ensure that the required voltage of the compressor is being supplied at all times. Low or high voltage can detrimentally affect the refrigeration unit. All units should be plugged into a grounded and properly-sized electrical outlet with appropriate overcurrent protection. Please refer to the electrical requirement on the nameplate of the unit. Please make sure that your unit has its own dedicated outlet. Do not use an extension cord.

## TEMPERATURE CONTROLS

The temperature controls are factory-set to maintain an average temperature of 38°F in refrigeration. To maintain a different temperature, adjust it on the temperature controller—see *manual of temperature controller*.

## CAUTION

Setting the temperature control to the coldest setting may cause the evaporator coil to freeze and ice up. This will eventually result in a warmer cabinet temperature.



## LOADING PRODUCT

Shelves have been factory-installed for your convenience. Before loading shelves, please be sure that all shelf clips are completely fastened in their correct locations. It is important that all shelves rest completely level before stocking your cabinet with product. In order to maintain correct air flow inside the unit, please be sure to leave two to four (2 to 4) inches of space between the back wall and stored product. Blocking the evaporator fans will result in a warmer cabinet temperature, and ultimately compressor failure.

## DEFROST SYSTEMS

Refrigerator coils are kept below the freezing point (32°F). During compressor down-time, the evaporator fan continues to circulate air through the evaporator coil. This air circulation raises the coil temperature above the freezing point, melting any accumulated frost. Run-off water is drained into the evaporator pan and evaporated. Freezer coils are defrosted electrically. Automatic defrost timers are built-in to the refrigeration system and may not be adjusted. The defrost timers automatically initiate at pre-set intervals and for a pre-determined duration.

**PLEASE NOTE:** excessive door opening should be avoided in order to maintain cabinet temperature and to eliminate the possibility of coil freeze-up.

## LOADING FOOD PANS

Pizza prep units and sandwich prep units are designed to function with all pans in place, even if some pans are to be left empty. For maximum food freshness, fill the pans only with an amount that can be used in a specific usage period. During non-use, please close the insulated lid cover.

## REVERSING THE DOORS (OPTIONAL)

**Note:** this only applies to the single door units.

**Only perform these steps with another person present to ensure the door does not fall over.**

1. Open the door.
2. Remove the screws from the top panel, then open the top panel.
3. Remove the screws of the bottom louver, then remove the louver.
4. Unscrew all of the screws from the upper hinge
5. Unscrew all of the screws from the lower hinge and remove the door and hinges.
6. Place the former upper hinge at the bottom of the unit, parallel to where the lower hinge is, do the same with the former lower hinge except for the top. Screw the hinges into place.
7. Reassemble the door so it is facing the opposite direction.
8. Reassemble the top panel and the lower louver.
9. The door is now reversed.

# ***Maintenance***

---

## **CLEANING THE CONDENSER COIL**

- For efficient operation, it is important that the condenser surface be kept free of dust, dirt, and lint.
- We recommend cleaning the condenser coil and fins at least once per month.
- Clean with a commercial condenser coil cleaner, available from any kitchen equipment retailer. Brush the condenser fins from top to bottom, not side to side.
- After cleaning, straighten any bent condenser fins with a fin comb.

## **CLEANING THE FAN BLADE AND MOTOR**

- If necessary, clean the fan blades and motor with a soft cloth, If it is necessary to wash the fan blades, cover the fan motor to prevent moisture damage.

## **CLEANING THE INTERIOR OF UNIT**

- When cleaning the cabinet interior, use a solvent of warm water and mild soap.
- Do not use steel wool, caustic soap, abrasive cleaners, or bleach that may damage the stainless steel surface.
- Wash door gaskets on a regular basis, preferably weekly. Simply remove door gasket from the frame of the door, soak in warm water and soap for thirty (30) minutes, dry with soft cloth, and replace.
- Check door gaskets for proper seal after they are replaced.
- Periodically remove the shelves and pilasters from the unit and clean them with mild soap and warm water. To remove the pilasters, first remove the shelves and shelf brackets. Then, simply lift the pilaster up and out.

## **WARNING**

**Disconnect power cord before cleaning any parts of the unit.**

# ***Troubleshooting***

---

**Before requesting any service on your unit, please check the following points. Please note that this guide serve only as a reference for solutions to common problems.**

## Troubleshooting

SYMPTOM	POSSIBLE CAUSE	CORRECTIVE ACTION
Compressor not running.	Fuse blown or circuit breaker tripped.	Replace fuse or reset circuit breaker.
	Power cord unplugged.	Plug in power cord.
	Thermostat set too high.	Set thermostat to lower temperature.
	Cabinet in defrost cycle.	Wait for defrost cycle to finish.
Condensing unit runs for long periods of time.	Excessive amount of warm product placed in cabinet.	Allow adequate time for product to cool down.
	Prolonged door opening or door ajar.	Ensure doors are closed when not in use. Avoid opening doors for long periods of time.
	Door gasket(s) not sealing properly.	Ensure gaskets are snapped in completely. Remove gasket and wash with soap and water. Check condition of gasket and replace if necessary.
	Dirty condenser coil.	Clean the condenser coil.
	Evaporator coil iced over.	Unplug unit and allow coil to Defrost. Make sure thermostat is not set too cold. Ensure that door gasket(s) are sealing properly.
Cabinet is noisy.	Loose part(s).	Locate and tighten loose part(s).
	Tubing vibration.	Ensure tubing is free from contact with other tubing or components.

# Troubleshooting

Cabinet temperature is too warm.	Thermostat set too warm.	Set thermostat to lower temperature.
	Blocking air flow.	Re-arrange product to allow for proper air flow. Make sure there is at least four inches of clearance from evaporator.
	Excessive amount of warm product placed in cabinet.	Allow adequate time for product to cool down.
	Fuse blown or circuit breaker tripped.	Replace fuse or reset circuit breaker.
	Dirty condenser coil.	Clean the condenser coil.
	Prolonged door opening or door ajar.	Ensure doors are closed when not in use. Avoid opening doors for long periods of time.
	Evaporator coil iced over.	(see above).

**For service call 1-800-465-0234.**

# Controller Instructions

Digital controller model: PJEZ for cooler



**Dimensioni (mm) / Dimensions (mm)**

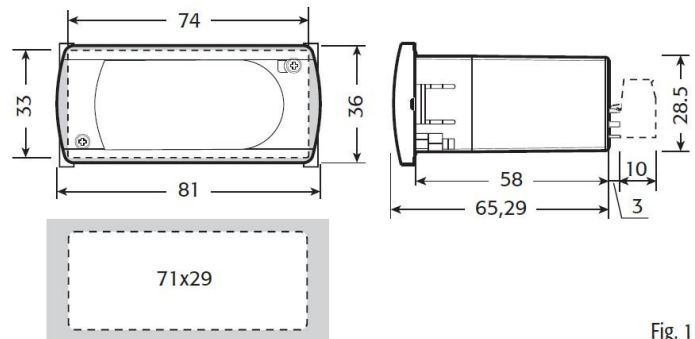







Fig. 1

# Controller Instructions



## Display and functions

During normal operation, the controller displays the value of the probe set using parameter/4(=1 ambient probe, default, = 2 second probe, = 3 third probe). In addition, the display has LEDs that indicate the activation of the control functions (see Table 1), while the 3 buttons can be used to activate/deactivate some of the functions(see Table 2).

### LED's and Associated Functions (Table 1)

Icon	Function	Normal Operation			Start Up
		ON	OFF	Blink	
	Compressor	On	Off	Request	ON
	Fan	On	Off	Request	ON
	Defrost	On	Off	Request	ON
AUX	Aux	Output On	Output Off	-	ON
	Alarm	All	No Alarm	-	ON
	Clock	RTC fitted and enabled, at least 1 time band set	RTC not fitted or disabled, not even 1 time band set	-	ON if RTC fitted

### Table of Functions activated by the buttons - Models S, X, Y, C (Table 2)

Button	Normal Operation		Start Up	
	Pressing the Button Alone	Pressed Together		
	Up ON/OFF	More than 3 sec: toggle ON/OFF	-  Pressed together Start parameter reset procedure	
	Down Defrost	More than 3 sec: start/stop defrost		
	Set Mute	- 1 sec.: display/set the set point. - more than 3 secs.: access parameter setting menu (enter password) - mute audible alarm (buzzer)	-	For 1 sec. RESET current EZY set

### Setting the set point (desired temperature)

- press **SET** for 1 sec, the set value will start flashing after a few moments;

# Controller Instructions

---

- increase or decrease the value using **UP** or **DOWN**;
- press **SET** to confirm the new value.

## Switching the device ON/OFF

Press **UP** for more than 3 sec. The control and defrost algorithms are now disabled and the Instrument displays the message "OFF" alternating with the temperature read by the set probe

## Manual defrost

Press for **DOWN** more than 3 sec (the defrost starts only the temperature conditions are valid).

## Continuous cycle

Press **UP** and **DOWN** together for more than 3 sec

## Access and setting type F (frequent) and type C (configuration) parameters

1. press **SET** for 3 sec (the display will show "PS");
2. • to access the type F and C parameter menu, enter the password "22" using **UP/DOWN**, press **SET** to confirm;  
• to access the F parameter menu only, press **SET** (without entering the password);
3. scroll inside the parameter menu using **UP/DOWN**;  
• to display/set the values of the parameter displayed, press **SET**, then **UP/DOWN** and finally **SET** to confirm the changes (returning to the parameter menu).

To save all the new values and exit the parameter menu, press **SET** for 3 s;

To exit the menu without saving the changed values (exit by timeout) do not press any button for at least 60 s.

# Parts Breakdown

Model **PT-CN-1270-HC** 50042

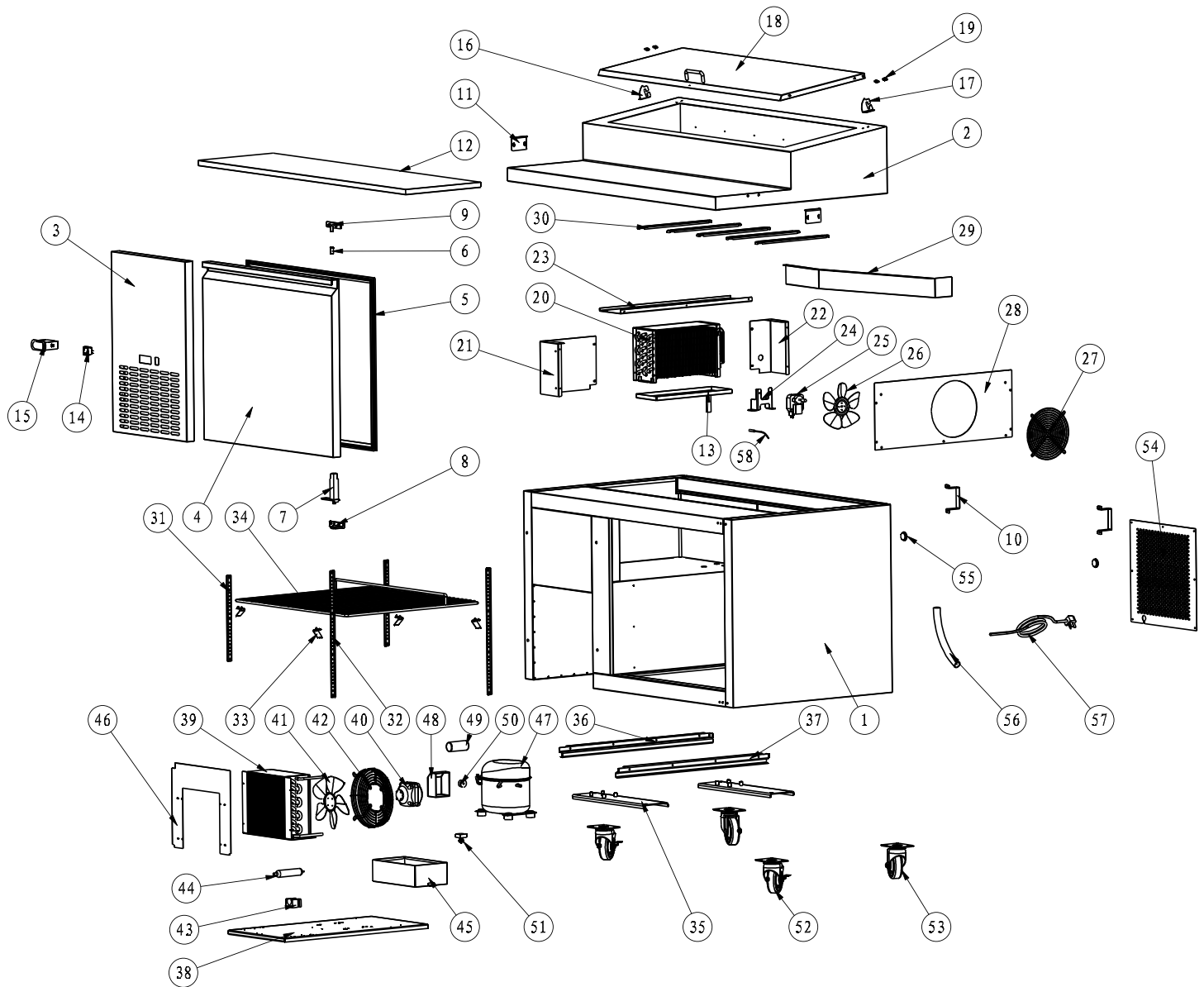

# Parts Breakdown

## Model PT-CN-1270-HC 50042

Item No.	Description	Position	Item No.	Description	Position	Item No.	Description	Position
AF159	Cabinet for 50042	1	AB476	Evaporator before June 2022 for 50042	20	AF180	Compressor Unit Installation Board for 50042	38
AF160	Top Rail for 50042	2	AS883	Evaporator after June 2022 for 50042	20	AS884	Condenser before June 2022 for 50042	39
AF161	Control Panel for 50042	3	AF169	Left Support of Evaporator Cover for 50042	21	AB159	Condenser after June 2022 for 50042	39
AF162	Door for 50042	4	AF170	Right Support of Evaporator Cover for 50042	22	AN216	Condenser Fan Motor before June 2022 for 50042	40
AB466	Gasket for 50042	5	AF171	Upper Support of Evaporator Cover for 50042	23	AL932	Condenser Fan Motor after June 2022 for 50042	40
AA388	Axis Cover for 50042	6	AF172	Evaporator Fan Motor Holder for 50042	24	AA208	Condenser Fan Blade for 50042	41
AA955	Left/Right Spring Hinge for 50042	7	AA128	Condenser Fan Motor before June 2022 for 50042	25	AA207	Condenser Fan Motor Cover for 50042	42
AA360	Hinge T for 50042	8	AL932	Condenser Fan Motor after June 2022 for 50042	25	AB595	Filter Fixer for 50042	43
AF070	Hinge X for 50042	9	AA962	Blade of Evaporator Fan Motor for 50042	26	AB594	Filter D25x160-B for 50042	44
AF080	Stand Off Bracket for 50042	10	AA971	Evaporator Fan Motor Cover for 50042	27	AA874	Outer Drain Pan for 50042	45
AF163	Fixer for Cutting Board for 50042	11	AF173	Evaporator Cover for 50042	28	AF181	Air Shield Board for 50042	46
AF164	Cutting Board for 50042	12	AF174	Air Guide Sheet for 50042	29	AF182	Compressor before June 2022 for 50042	47
AF165	Inner Drain Pan for 50042	13	AF175	Pan Bracket-25 for 50042	30	AI386	Compressor after June 2022 for 50042	47
AA124	Power Switch for 50042	14	AF090	K Strip-3 Holes for 50042	31	26246	Caster with Brake for 50042	52
AA123	Carel Controller PYGX1Z0502 before June 2022 for 50042	15	AF176	K Strip-4 Holes for 50042	32	26247	Caster without Brake for 50042	53
AL929	Dixell Temperature Controller - XR02 after June 2022 for 50042	15	26884	K Clip for 50042	33	AF183	Back Grill for 50042	54
AF166	Left Lid Hinge for 50042	16	AB487	Shelf for 50042	34	AB169	Foaming Hole Cover for 50042	55
AF167	Right Lid Hinge for 50042	17	AF177	Castor Support for 50042	35	AA133	Drain Hose for 50042	56
AF168	Lid for 50042	18	AF178	Left Compressor Unit Track for 50042	36	AA135	Power Cord for 50042	57
AB475	Lid Hinge Axis for 50042	19	AF179	Right Compressor Unit Track for 50042	37	AA379	Temperature Probe for 50042	58



# Parts Breakdown

**Model PT-CN-1829-HC** 50043

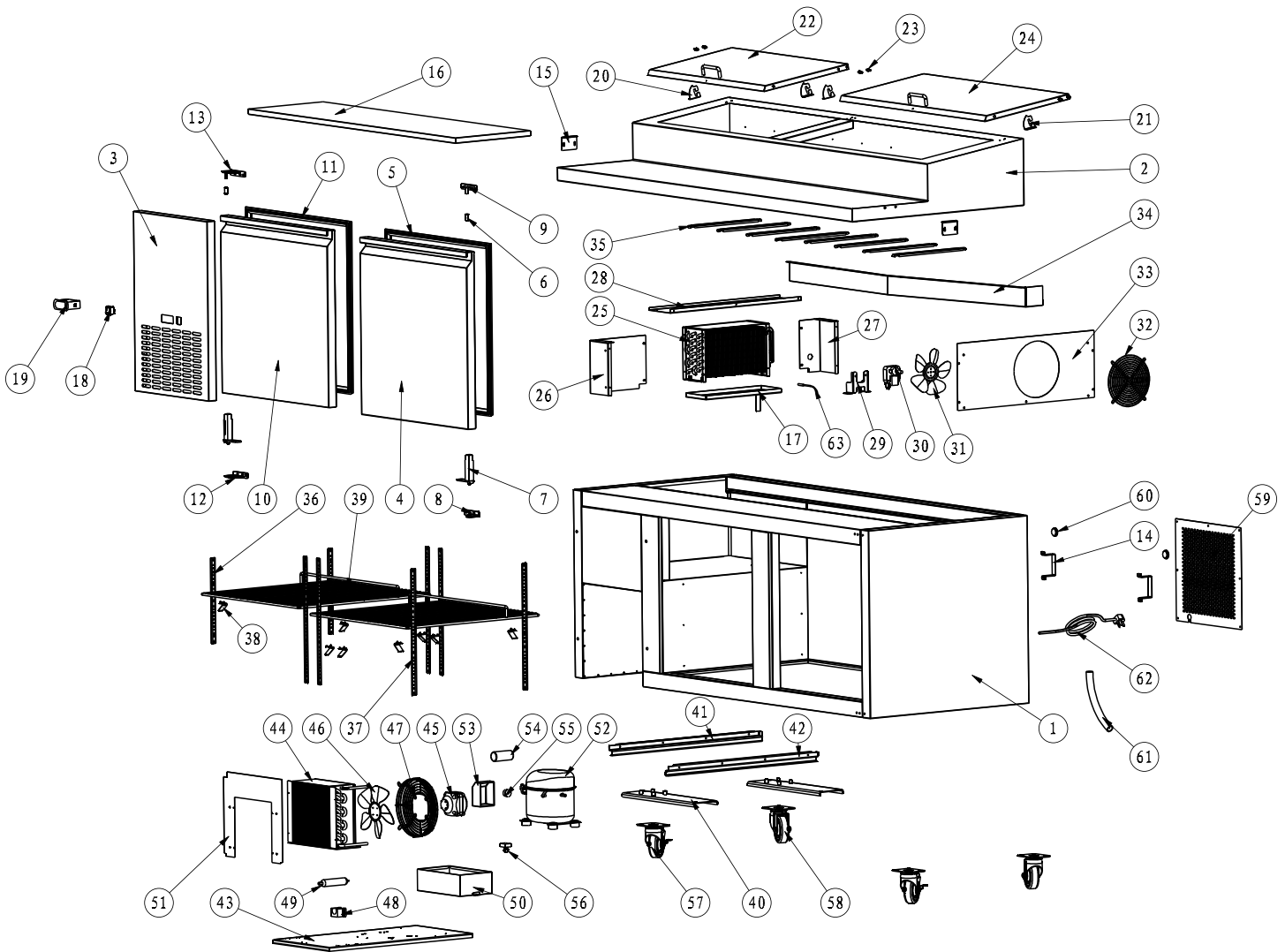

# Parts Breakdown

## Model PT-CN-1829-HC 50043

Item No.	Description	Position	Item No.	Description	Position	Item No.	Description	Position
AF184	Cabinet for 50043	1	AF190	Lid for 50043	22	AF179	Right Compressor Unit Track for 50043	42
AF185	Top Rail for 50043	2	AB475	Lid Hinge Axis for 50043	23	AF180	Compressor Unit Installation Board for 50043	43
AF161	Control Panel for 50043	3	AF191	Lid for 50043	24	AA250	Condenser before June 2022 for 50043	44
AF186	Right Door for 50043	4	AB511	Evaporator before June 2022 for 50043	25	AB527	Condenser after June 2022 for 50043	44
AB500	Gasket for 50043	5	AS883	Evaporator after June 2022 for 50043	25	AS885	Condenser Fan Motor before June 2022 for 50043	45
AA388	Axis Cover for 50043	6	AF192	Left Support of Evaporator Cover for 50043	26	26675	Condenser Fan after June 2022 for 50043	45
AA955	Left/Right Spring Hinge for 50043	7	AF193	Right Support of Evaporator Cover for 50043	27	AA248	Condenser Fan Blade for 50043	46
AA360	Hinge T for 50043	8	AF171	Upper Support of Evaporator Cover for 50043	28	AA249	Condenser Fan Motor Cover for 50043	47
AF070	Hinge X for 50043	9	AF172	Evaporator Fan Motor Holder for 50043	29	AB595	Filter Fixer for 50043	48
AF187	Left Door for 50043	10	AA128	Condenser Fan Motor before June 2022 for 50043	30	AB594	Filter D25x160-B for 50043	49
AB500	Gasket for 50043	11	AL932	Condenser Fan Motor after June 2022 for 50043	30	AA874	Outer Drain Pan for 50043	50
AA360	Hinge T for 50043	12	AA962	Blade of Evaporator Fan Motor for 50043	31	AF181	Air Shield Board for 50043	51
AB200	Hinge W for 50043	13	AA971	Evaporator Fan Motor Cover for 50043	32	AS886	Compressor before June 2022 for 50043	52
AF080	Stand Off Bracket for 50043	14	AF173	Evaporator Cover for 50043	33	AI971	Compressor after June 2022 for 50043	52
AF163	Fixer for Cutting Board for 50043	15	AF174	Air Guide Sheet for 50043	34	26246	Caster with Brake for 50043	57
AF188	Cutting Board for 50043	16	AF175	Pan Bracket-25 for 50043	35	26247	Caster without Brake for 50043	58
AF189	Inner Drain Pan for 50043	17	AF090	K Strip-3 Holes for 50043	36	AF183	Back Grill for 50043	59
AA124	Power Switch for 50043	18	AF176	K Strip-4 Holes for 50043	37	AB169	Foaming Hole Cover for 50043	60
AA123	Carel Controller PYGX1Z0502 before June 2022 for 50043	19	26884	K Clip for 50043	38	AA133	Drain Hose for 50043	61
AL929	Dixell Temperature Controller - XR02 after June 2022 for 50043	19	AB522	Shelf for 50043	39	AA135	Power Cord for 50043	62
AF166	Left Lid Hinge for 50043	20	AF177	Castor Support for 50043	40	AA379	Temperature Probe for 50043	63
AF167	Right Lid Hinge for 50043	21	AF178	Left Compressor Unit Track for 50043	41			

# Parts Breakdown

**Model PT-CN-2337-HC 50044**

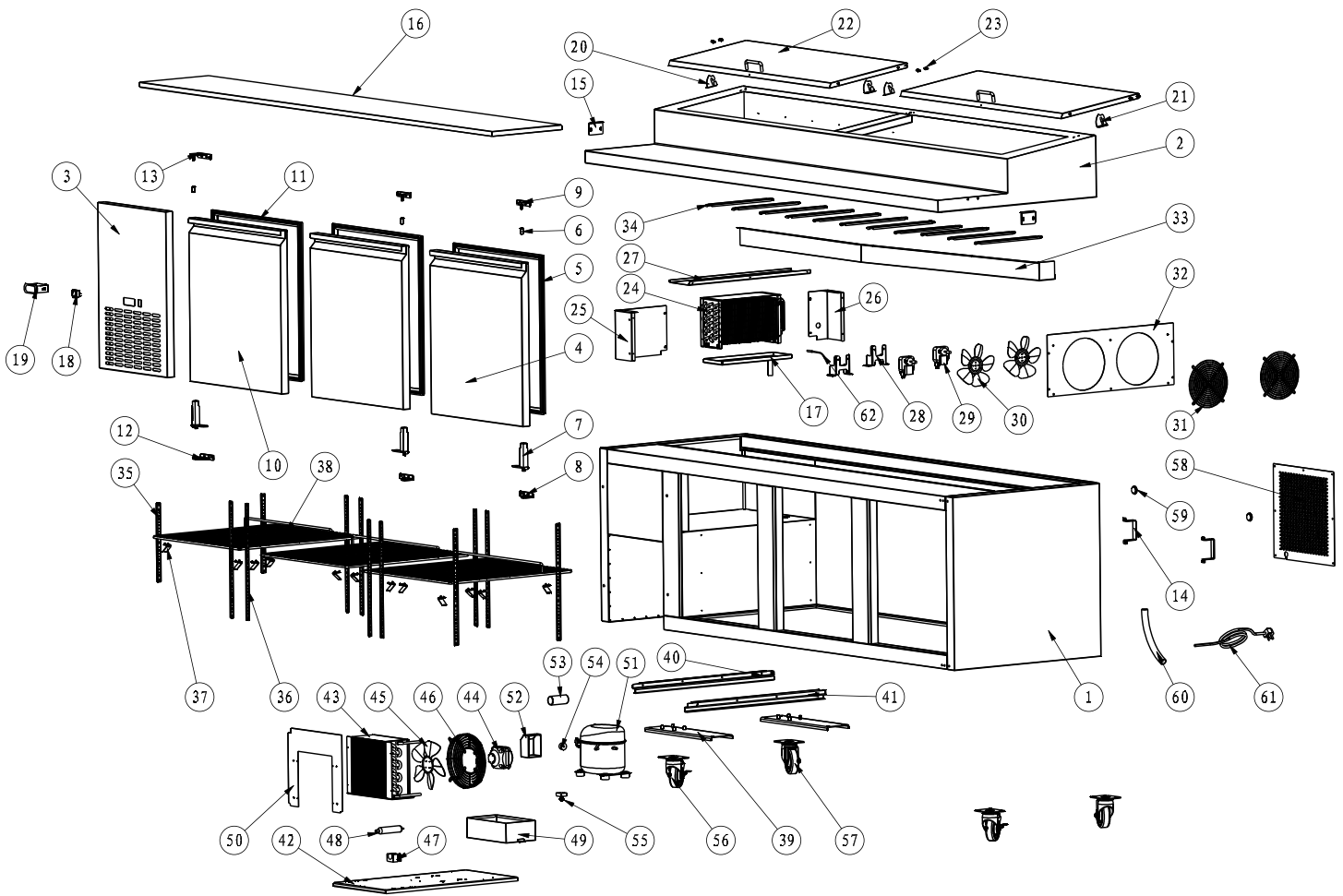

# Parts Breakdown

## Model PT-CN-2337-HC 50044

Item No.	Description	Position	Item No.	Description	Position	Item No.	Description	Position
AF194	Cabinet for 50044	1	AF167	Right Lid Hinge for 50044	21	AF179	Right Compressor Unit Track for 50044	41
AF195	Top Rail for 50044	2	AF200	Lid for 50044	22	AF180	Compressor Unit Installation Board for 50044	42
AF161	Control Panel for 50044	3	AB475	Lid Hinge Axis for 50044	23	AA250	Condenser before June 2022 for 50044	43
AF196	Right Door for 50044	4	AB546	Evaporator for 50044	24	AB527	Condenser after June 2022 for 50044	43
AB536	Gasket for 50044	5	AF201	Left Support of Evaporator Cover for 50044	25	AS885	Condenser Fan Motor before June 2022 for 50044	44
AA388	Axis Cover for 50044	6	AF202	Right Support of Evaporator Cover for 50044	26	26675	Condenser Fan after June 2022 for 50044	44
AA955	Left/Right Spring Hinge for 50044	7	AF171	Upper Support of Evaporator Cover for 50044	27	AA248	Condenser Fan Blade for 50044	45
AA360	Hinge T for 50044	8	AF172	Evaporator Fan Motor Holder for 50044	28	AA249	Condenser Fan Motor Cover for 50044	46
AF070	Hinge X for 50044	9	AS887	Evaporator Fan Motor before June 2022 for 50044	29	AB595	Filter Fixer for 50044	47
AF197	Left Door for 50044	10	AL932	Condenser Fan Motor after June 2022 for 50044	29	AB594	Filter D25x160-B for 50044	48
AB536	Gasket for 50044	11	AA962	Blade of Evaporator Fan Motor for 50044	30	AA874	Outer Drain Pan for 50044	49
AA360	Hinge T for 50044	12	AA971	Evaporator Fan Motor Cover for 50044	31	AF181	Air Shield Board for 50044	50
AB200	Hinge W for 50044	13	AF173	Evaporator Cover for 50044	32	AE915	Compressor (T6217Z) before June 2022 for 50044	51
AF080	Stand Off Bracket for 50044	14	AF174	Air Guide Sheet for 50044	33	AI319	Compressor after June 2022 for 50044	51
AF163	Fixer for Cutting Board for 50044	15	AF175	Pan Bracket-25 for 50044	34	26246	Caster with Brake for 50044	56
AF198	Cutting Board for 50044	16	AF090	K Strip-3 Holes for 50044	35	26247	Caster without Brake for 50044	57
AF199	Inner Drain Pan for 50044	17	AF176	K Strip-4 Holes for 50044	36	AF183	Back Grill for 50044	58
AA124	Power Switch for 50044	18	26884	K Clip for 50044	37	AB169	Foaming Hole Cover for 50044	59
AA123	Carel Controller PYGX1Z0502 before June 2022 for 50044	19	AB557	Shelf for 50044	38	AA133	Drain Hose for 50044	60
AL929	Dixell Temperature Controller - XR02 after June 2022 for 50044	19	AF177	Castor Support for 50044	39	AA135	Power Cord for 50044	61
AF166	Left Lid Hinge for 50044	20	AF178	Left Compressor Unit Track for 50044	40	AA379	Temperature Probe for 50044	62

# Electrical Schematics

**Model PT-CN-1270-HC** 50042

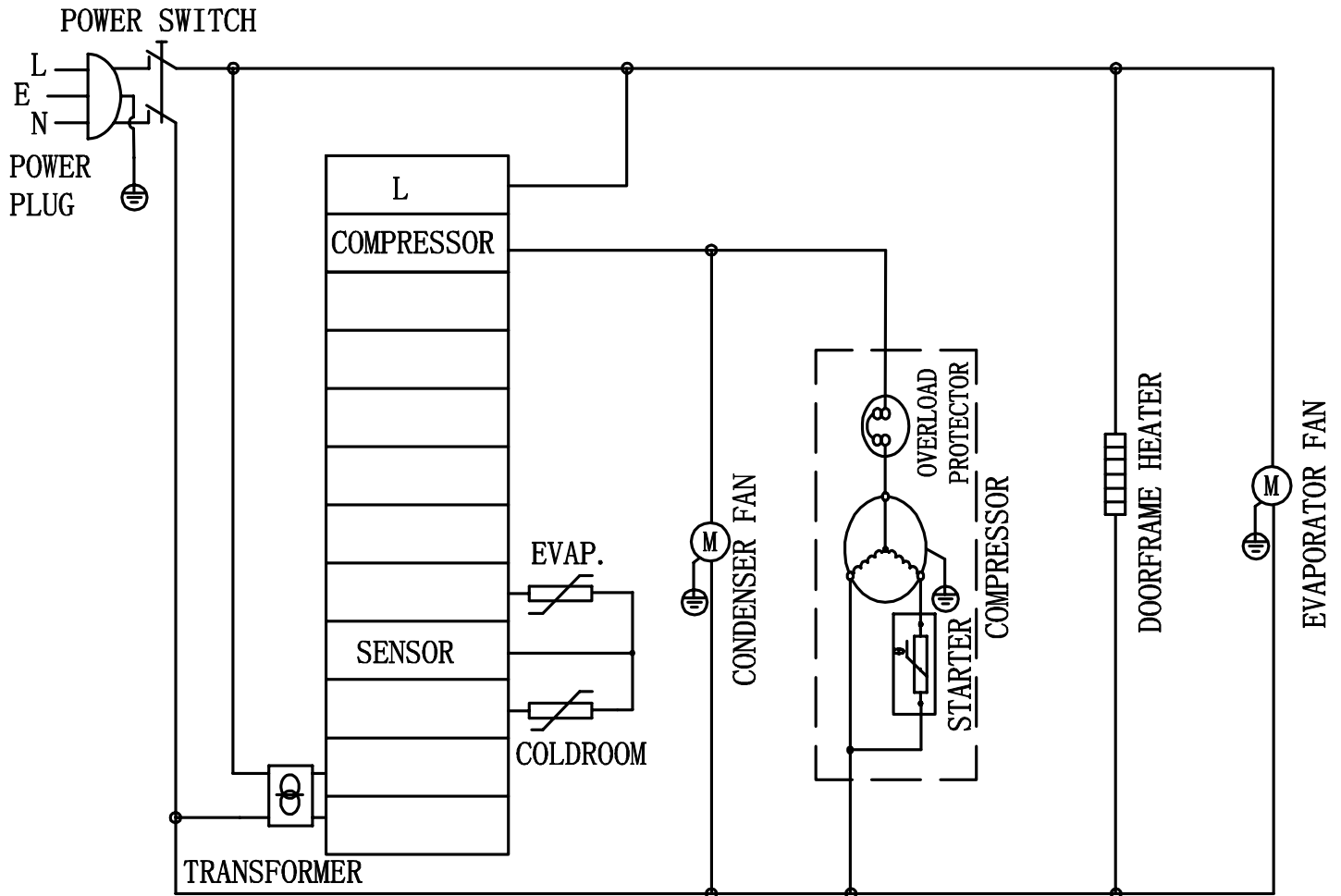

NEMA  
5 - 15P  
125VAC / 15 AMP

# Electrical Schematics

**Model PT-CN-1829-HC** 50043

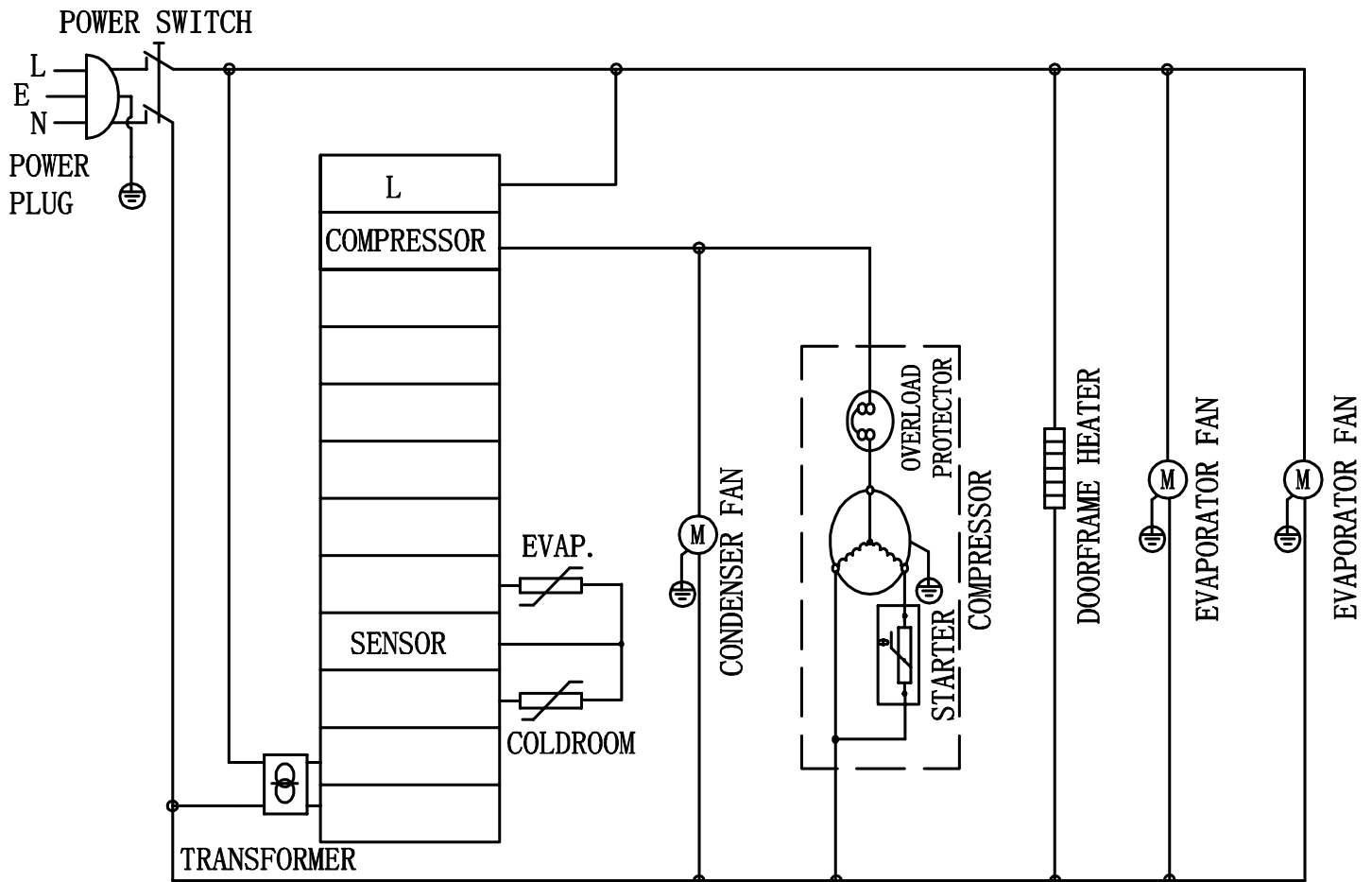

**NEMA**  
 5 - 15P  
 125VAC / 15 AMP

# Electrical Schematics

**Model PT-CN-2337-HC** 50044

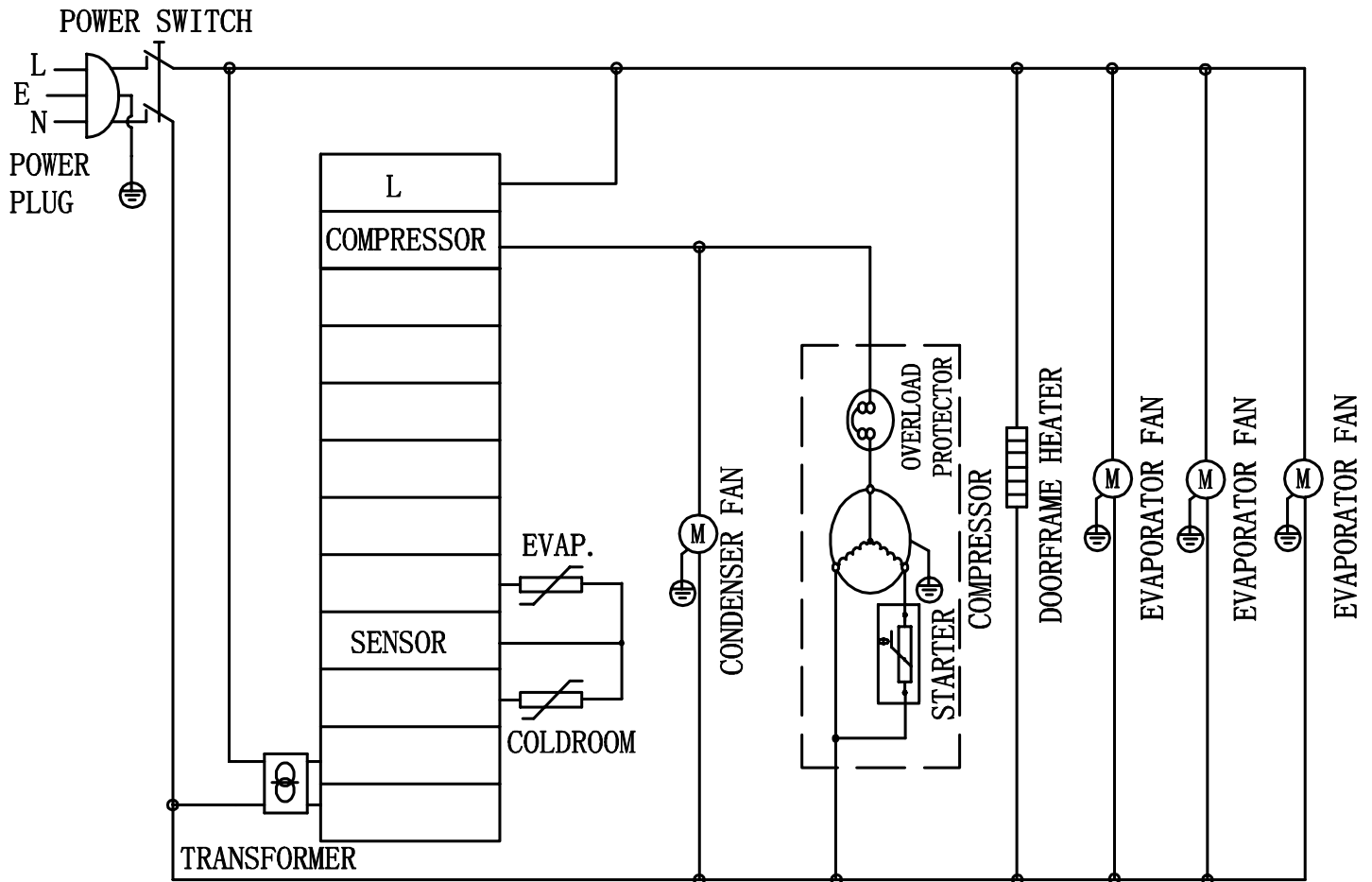

NEMA  
5 - 15P  
125VAC / 15 AMP











# Warranty Registration

Thank you for purchasing an Omcan product. To register your warranty for this product, complete the information below, tear off the card at the perforation and then send to the address specified below. You can also register online by visiting:

Merci d'avoir acheté un produit Omcan. Pour enregistrer votre garantie pour ce produit, complétez les informations ci-dessous, détachez la carte au niveau de la perforation, puis l'envoyer à l'adresse spécifiée ci-dessous. Vous pouvez également vous inscrire en ligne en visitant:

Gracias por comprar un producto Omcan usted. Para registrar su garantía para este producto, complete la información a continuación, cortar la tarjeta en la perforación y luego enviarlo a la dirección indicada a continuación. También puede registrarse en línea en:

<https://omcan.com/warranty-registration/>

For mailing in Canada

Pour postale au Canada

Por correo en Canadá

**OMCAN**

PRODUCT WARRANTY REGISTRATION

3115 Pepper Mill Court,  
Mississauga, Ontario  
Canada, L5L 4X5

For mailing in the US

Pour diffusion aux États-Unis

Por correo en los EE.UU.

**OMCAN**

PRODUCT WARRANTY REGISTRATION

4450 Witmer Industrial Estates, Unit 4,  
Niagara Falls, New York  
USA, 14305

*or email to: [service@omcan.com](mailto:service@omcan.com)*



Purchaser's Information

Name: \_\_\_\_\_

Address: \_\_\_\_\_

City: \_\_\_\_\_ Province or State: \_\_\_\_\_ Postal or Zip: \_\_\_\_\_

Country: \_\_\_\_\_

Dealer from which Purchased: \_\_\_\_\_

Dealer City: \_\_\_\_\_ Dealer Province or State: \_\_\_\_\_

Invoice: \_\_\_\_\_

Model Name: \_\_\_\_\_ Model Number: \_\_\_\_\_

Machine Description: \_\_\_\_\_

Date of Purchase (MM/DD/YYYY): \_\_\_\_\_

Would you like to extend the warranty?  Yes  No

Company Name: \_\_\_\_\_

Telephone: \_\_\_\_\_

Email Address: \_\_\_\_\_

Type of Company:

Restaurant  Bakery  Deli

Butcher  Supermarket  Caterer

Institution (specify): \_\_\_\_\_

Other (specify): \_\_\_\_\_

Serial Number: \_\_\_\_\_

Date of Installation (MM/DD/YYYY): \_\_\_\_\_

**Thank you for choosing Omcan | Merci d'avoir choisi Omcan | Gracias por elegir Omcan**



Since 1951 Omcan has grown to become a leading distributor of equipment and supplies to the North American food service industry. Our success over these many years can be attributed to our commitment to strengthen and develop new and existing relationships with our valued customers and manufacturers. Today with partners in North America, Europe, Asia and South America, we continually work to improve and grow the company. We strive to offer customers exceptional value through our qualified local sales and service representatives who provide convenient access to over 6,500 globally sourced products.

---

Depuis 1951 Omcan a grandi pour devenir un des "leaders" de la distribution des équipements et matériel pour l'industrie des services alimentaires en Amérique du Nord. Notre succès au cours de ces nombreuses années peut être attribué à notre engagement à renforcer et à développer de nouvelles et existantes relations avec nos clients et les fabricants de valeur. Aujourd'hui avec des partenaires en Amérique du Nord, Europe, Asie et Amérique du Sud, nous travaillons continuellement à améliorer et développer l'entreprise. Nous nous efforçons d'offrir à nos clients une valeur exceptionnelle grâce à nos ventes locales qualifiées et des représentants de service qui offrent un accès facile à plus de 6500 produits provenant du monde entier.

---

Desde 1951 Omcan ha crecido hasta convertirse en un líder en la distribución de equipos y suministros de alimentos en América del Norte industria de servicios. Nuestro éxito en estos años se puede atribuir a nuestro compromiso de fortalecer y desarrollar nuevas relaciones existentes con nuestros valiosos clientes y fabricantes. Hoy con socios de América del Norte, Europa, Asia y América del Sur, que trabajan continuamente para mejorar y crecer la empresa. Nos esforzamos por ofrecer a nuestros clientes valor excepcional a través de nuestro local de ventas y representantes de los servicios que proporcionan un fácil acceso a más de 6,500 productos con origen a nivel mundial.

