



Serving the Food Industry Since 1951

Gas Overfired Broiler, 100,000 BTU, NG

ITEM: 48329
MODEL: CE-CN-0036U-NG



Precision Searing, High-Output Performance

Engineered for high-volume commercial kitchens, this powerful overfired broiler delivers intense infrared heat to achieve perfect sears and locked-in flavor. With its durable stainless steel construction and rapid-heat technology, it provides the reliability and speed necessary for steakhouse-quality results in a fast-paced environment.

- Stainless steel structure with thick insulation for energy efficiency
- (3) 32,500 BTU radiant burners with ceramic tiles
- 500 – 900°C high intense infrared heat to penetrate food core
- Spring-balanced lifting system, easy to adjust
- Grills can be rolled out for easy loading, unloading and cleaning
- Grill stopper to prevent grills falling off
- 5-height locking position to have different temperature
- Electronic ignition to provide instant and safe lighting burners
- Stainless steel crumb tray to collect grease
- Instant heating within one minute
- Cold rolled steel grids to produce attractive grill marks on food

Telephone: 1-800-465-0234

Fax: (905) 607-0234

Email: sales@omcan.com

Website: www.omcan.com



Authorized Dealer



Made in China

TECHNICAL DRAWING

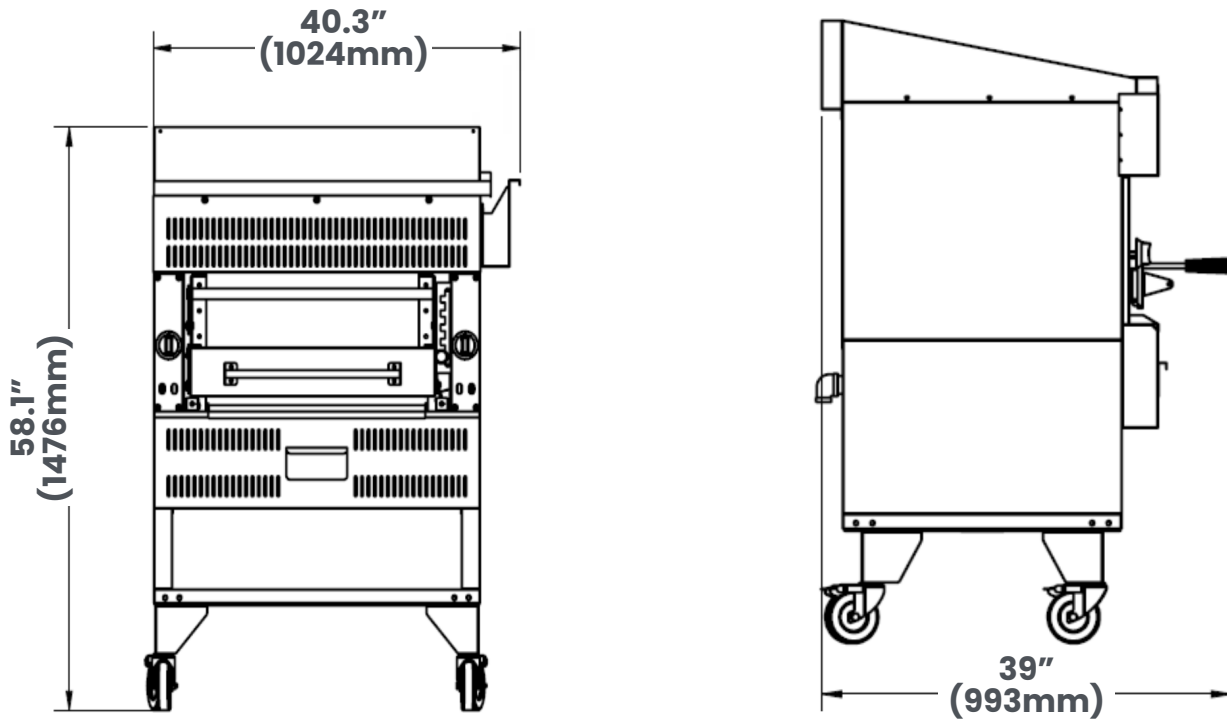

TECHNICAL SPECIFICATION

Item	48329
Model	CE-CN-0036U-NG
Output	100,000 BTU
Cooking Area	25.5" x 25" (648 x 635 mm)
Net Dimensions (WDH)	40" x 39" x 58" (1024 x 993 x 1476 mm)
Net Weight	655 lb (297 kg)

*Dimensions rounded up to the nearest tenth inch or millimeter.
Specifications subject to change without notice.*