



SERVING THE FOOD INDUSTRY SINCE 1951

Chamber Wok Ranges with Backsplash & Faucet Natural Gas

ITEM:	48411	48412	47726	48671	48413	48409	49042
MODEL:	CE-CN-WI0-NG	CE-CN-WI1-NG	CE-CN-W2L0-NG	CE-CN-W2L2-NG	CE-CN-W2L1-NG	CE-CN-W3L1-NG	CE-CN-W3L3-NG

48411



48412



47726



48671



48413



48409



49042



The durable and efficient Chamber Wok Ranges are valuable assets for any kitchen.

13" and 16" wok rings with an impressive total BTU deliver the high heat necessary for all your culinary endeavors. Crafted with a stainless steel faucet, backsplash, and pipe rack, this range guarantees longevity and practicality.

The adjustable gas valve and pilot ignition system provide easy heat control, ensuring precise cooking results every time.

Perfectly suited for most commercial kitchens, this wok range prioritizes safety with its water-cooled top and offers cost-effective operation with its natural gas fuel source. Whether you're stir-frying, deep-frying, or simmering, this versatile range excels in fulfilling your cooking needs effortlessly.

- Stainless steel faucet, backsplash,
- pipe rack, water cooled top
- Adjustable gas valve
- Pilot ignition

Telephone: 1-800-465-0234

Fax: (905) 607-0234

Email: sales@omcan.com

Website: www.omcan.com



Authorized Dealer



Made in China



(Updated: 2026.04, tp)

Page 1 / 10

TECHNICAL SPECIFICATIONS

Features	Single Chamber 13" Ring with 95,000 BTU	Single Chamber 16" Ring with 125,000 BTU	Two Chambers 13" Ring + 16" with 220,000 BTU
Item	48411	48412	48413
Model	CE-CN-W1L0-NG	CE-CN-W1L1-NG	CE-CN-W2L1-NG
Gas Type	Natural Gas		
Total BTU	95,000	125,000	220,000
Jet Burners	1		2
Pot Diameter	13" (330mm)	16" (406mm)	13" (330mm) 16" (406mm)
Net Weight	115 lb. (52 kg.)	121 lb. (54.8 kg.)	198 lb. (89.8 kg.)
Net Dimensions (WDH)	27.8" x 44" x 62" (707 x 1118 x 1575mm)		47.5" x 44" x 62" (1206 x 1118 x 1575mm)
Gross Weight	192 lb. (87 kg.)	198 lb. (89.8 kg.)	293 lb. (132.9 kg.)
Gross Dimensions (WDH)	31.5" x 47.2" x 39.4" (800 x 1200 x 1000 mm)		51.2" x 47.2" x 39.4" (1300 x 1200 x 1000 mm)

TECHNICAL SPECIFICATIONS

Features	Two Chambers 13" Ring + 13" with 190,000 BTU	Two Chambers 16" Ring + 16" with 250,000 BTU	Three Chambers 2x 13" Ring + 1x 16" with 315,000 BTU	Three Chambers 3 x 16" Ring with 375,000 BTU
Item	48413	48671	48409	49042
Model	CE-CN-W2L0-NG	CE-CN-W2L2-NG	CE-CN-W3L1-NG	CE-CN-W3L3-NG
Gas Type	Natural Gas			
Total BTU	190,000	250,000	315,000	375,000
Jet Burners	2		3	
Pot Diameter	13" (330mm) (2)	16" (406mm) (2)	13" (330mm) (2) 16" (406mm)	16" (406mm) (3)
Net Weight	192 lb (87 kg)	192 lb (87 kg)	207 lb (93.89 kg)	212 lb (96.2 kg)
Net Dimensions (WDH)	47.5" x 42.8" x 62" (1206 x 1118 x 1575mm)	47.5" x 42.8" x 62" (1206 x 1118 x 1575mm)	67.2" x 44" x 62" (1706 x 1118 x 1575 mm)	68" x 44" x 62" (1727 x 1118 x 1575 mm)

Dimensions rounded up to the nearest tenth inch or millimeter.
Specifications subject to change without notice.

DETAILS



Gas Valve



18 Tip Burner



28 Tip Burner



Water Inlet Valve

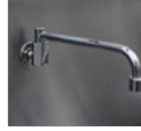

Faucet



Waterfall Back



Outlet Drain

Model Description:

CE-CN-W3L0

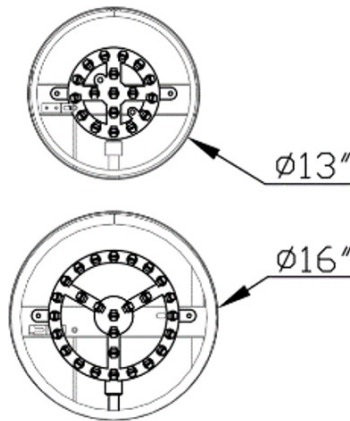
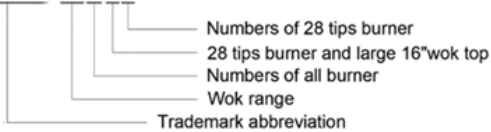

18 Tip jet burner at 13" wok top pot

28 Tip jet burner at 16" wok top pot

- This appliance is manufactured for commercial installation only, not intended for home use.
- 3/4" NPT rear gas connections. Supply gas pressure not to exceed 14" W.C.(1/2 PSI)
- Natural gas operating pressure - 5.0" W.C. Recommended supply pressure 7-9" W.C.
- Propane gas operating pressure - 10.0" W.C. Recommended supply pressure 11-12" W.C.
- A gas pressure regulator supplied with unit must be installed.
- Water inlet and drain outlet connect thread 1/2"NPT female
- An adequate ventilation system is required for Commercial Cooking Equipment.
- Require a 6" clearance at both side and rear adjacent to combustible construction

TECHNICAL DRAWING (48411)

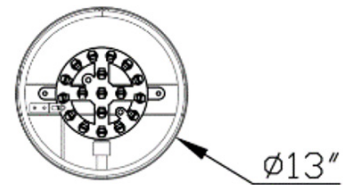
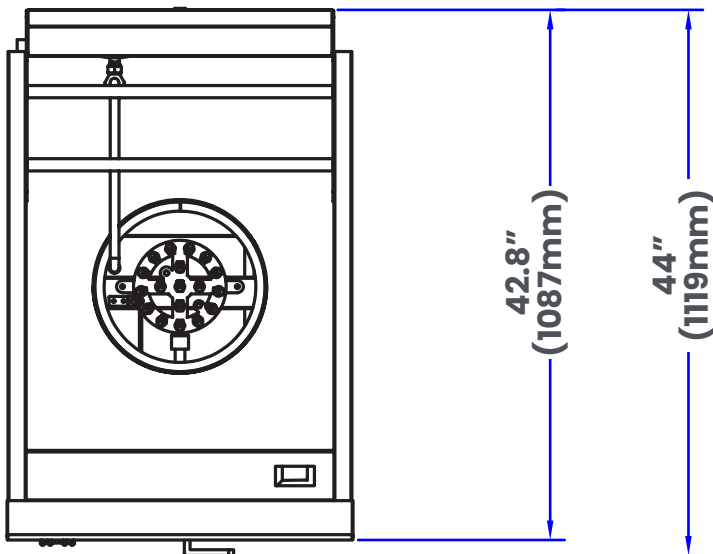
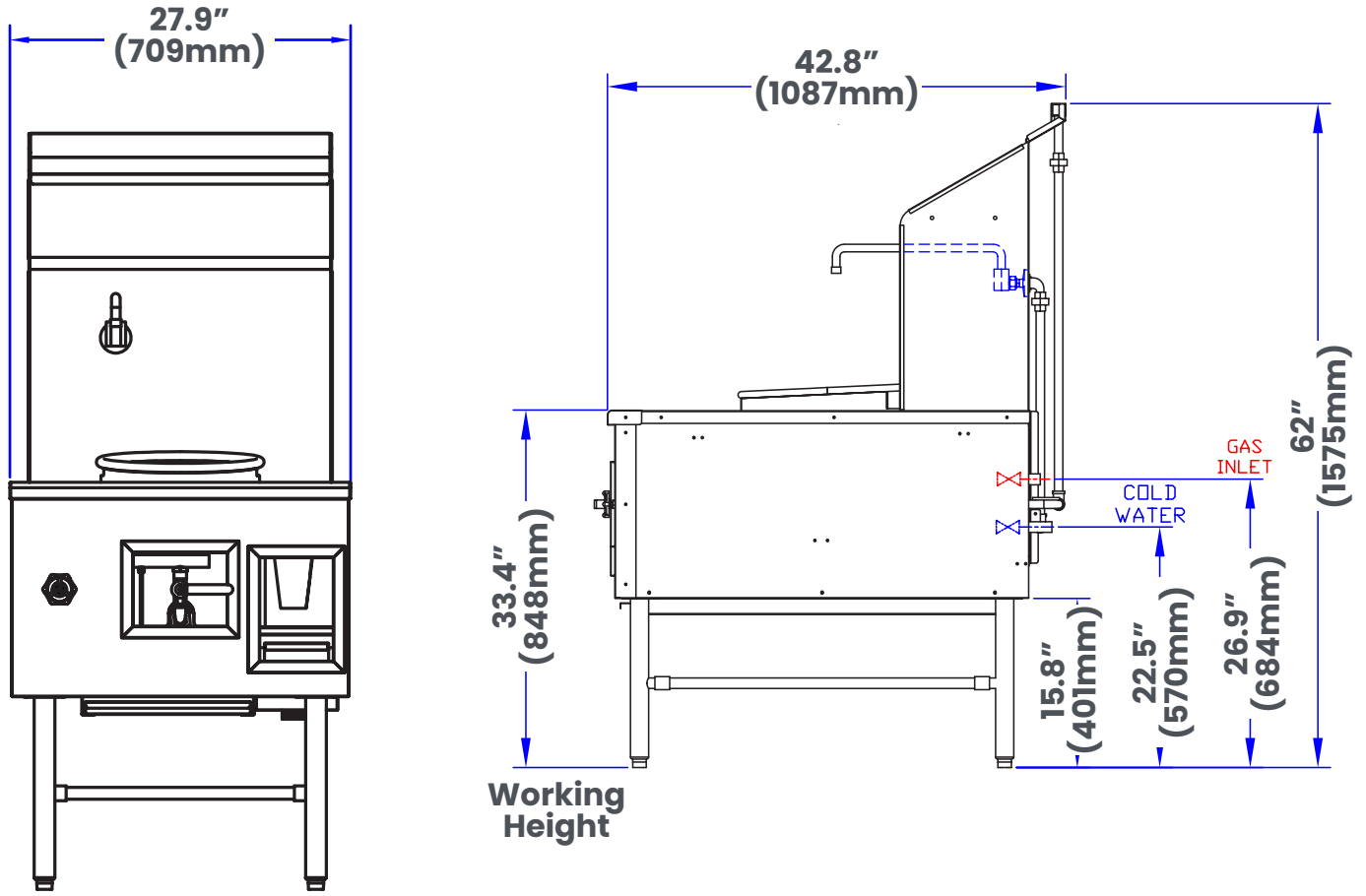

TECHNICAL DRAWING (48412)

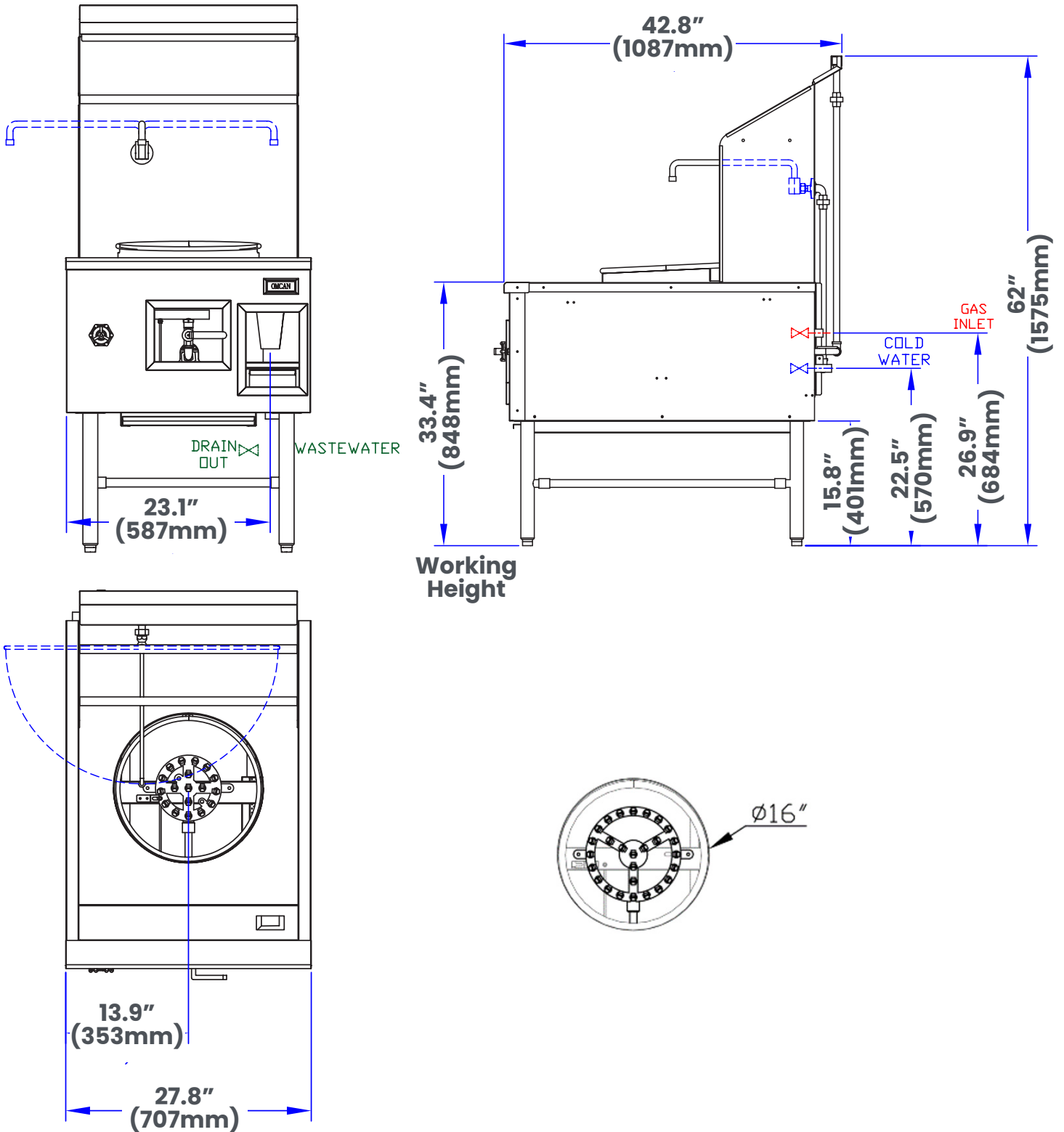

TECHNICAL DRAWING (47726)

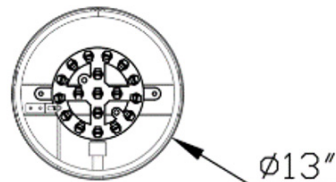
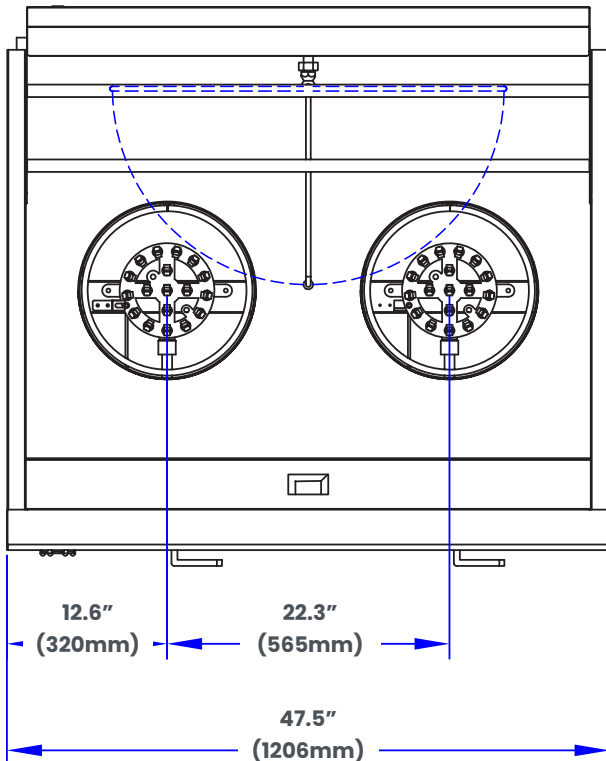
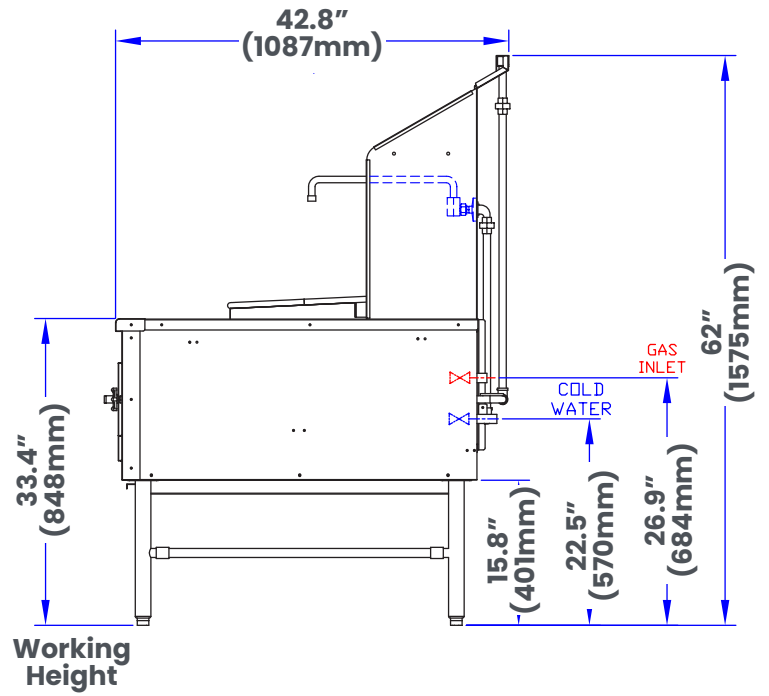
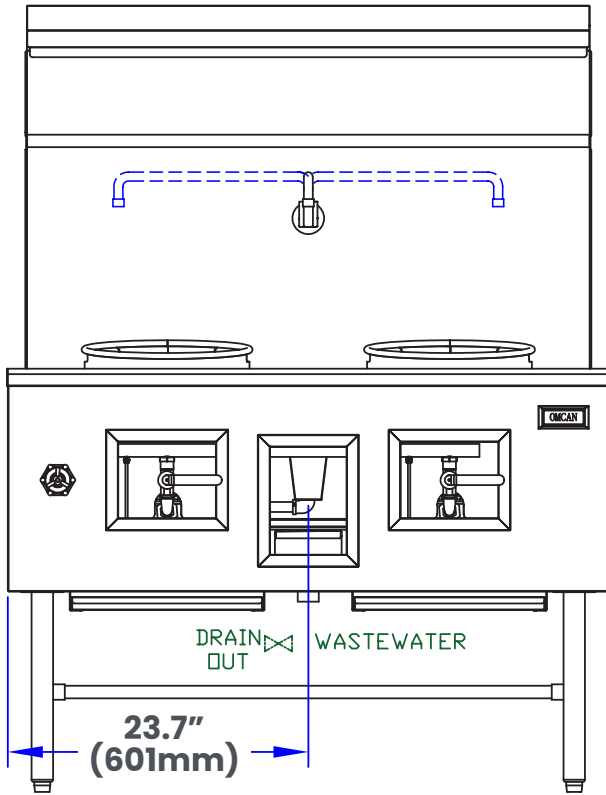

TECHNICAL DRAWING (48671)

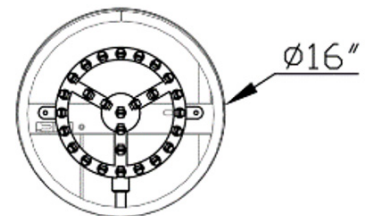
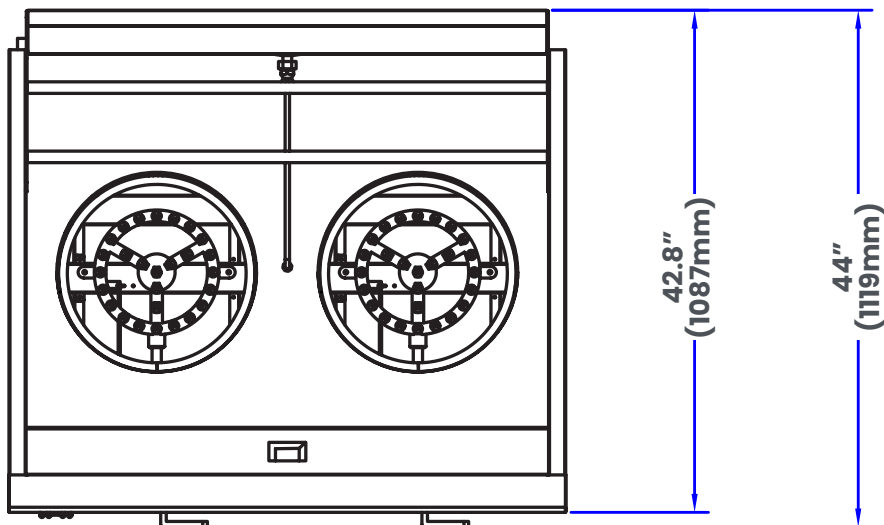
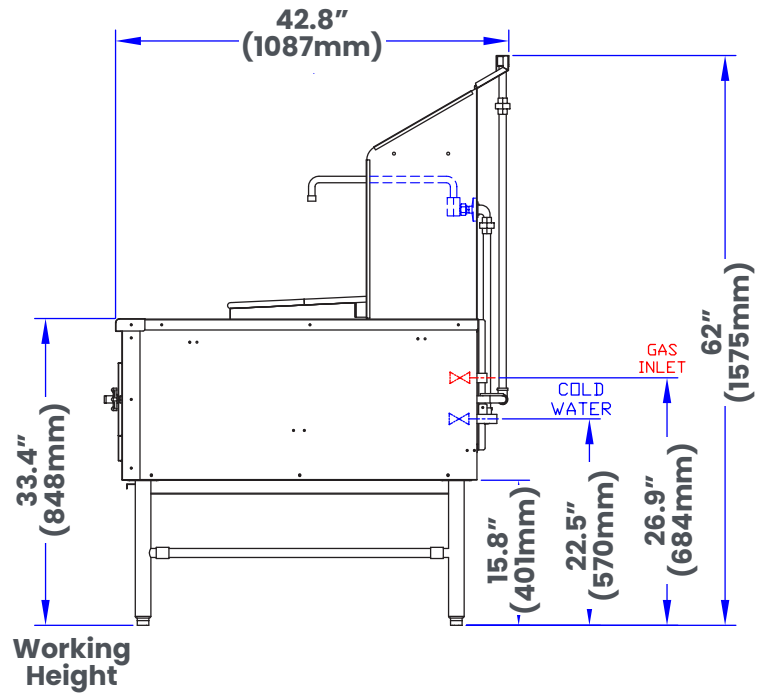
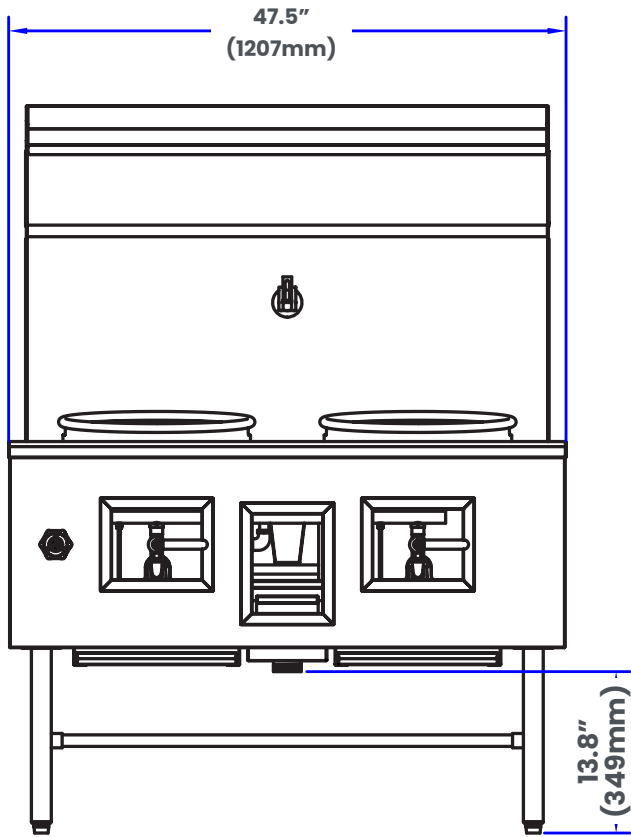

TECHNICAL DRAWING (48413)

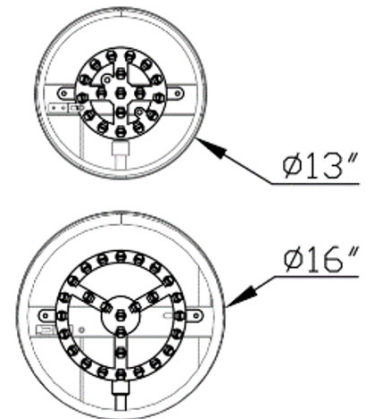
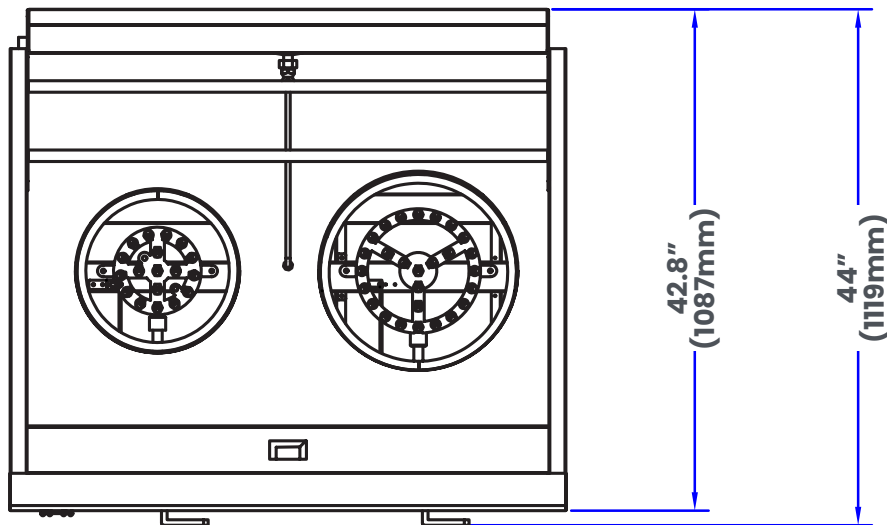
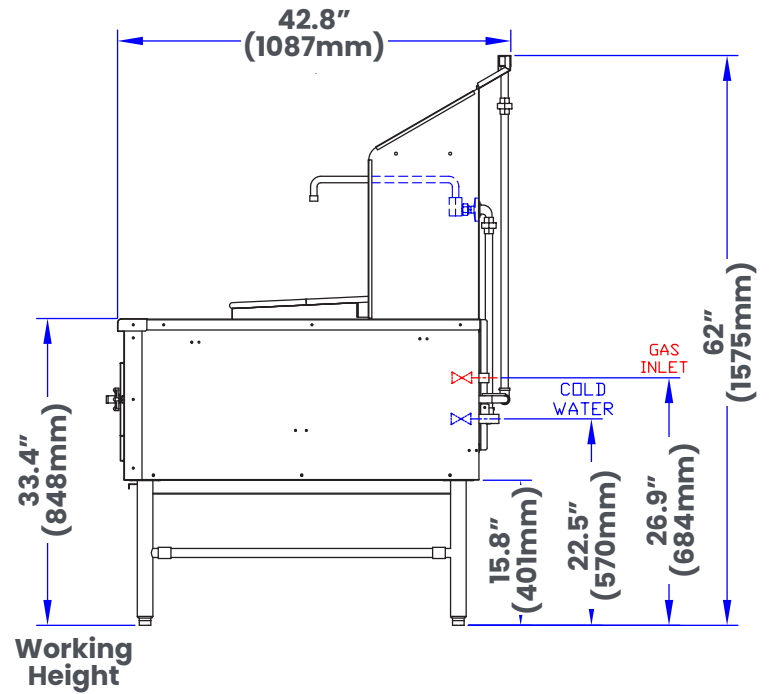
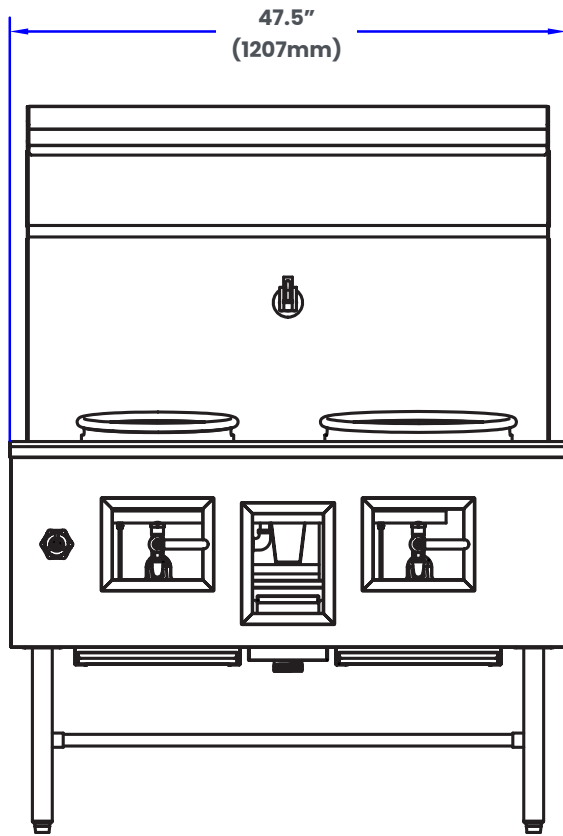

TECHNICAL DRAWING (48409)

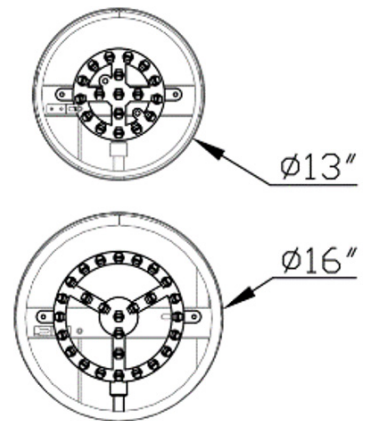
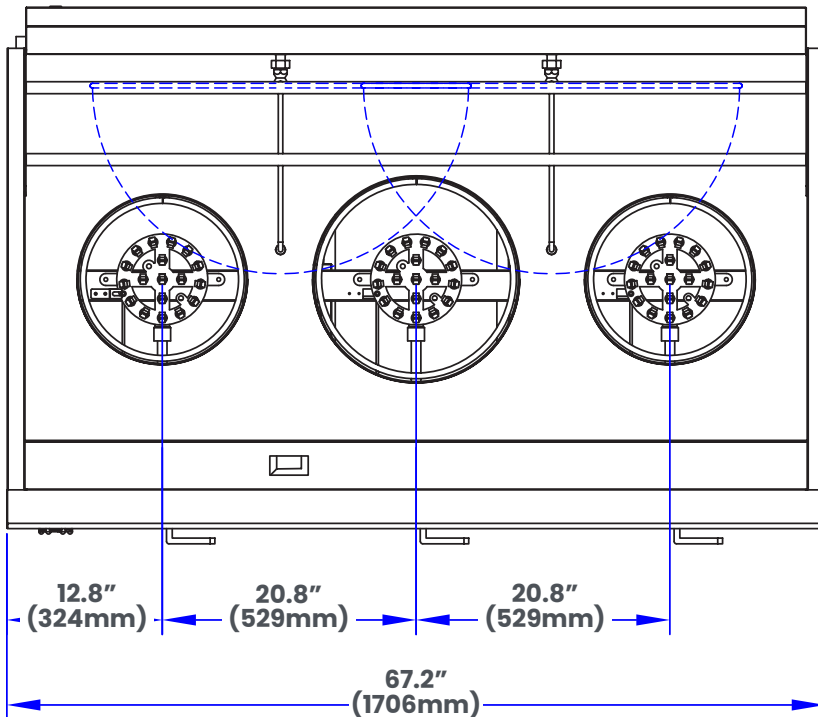
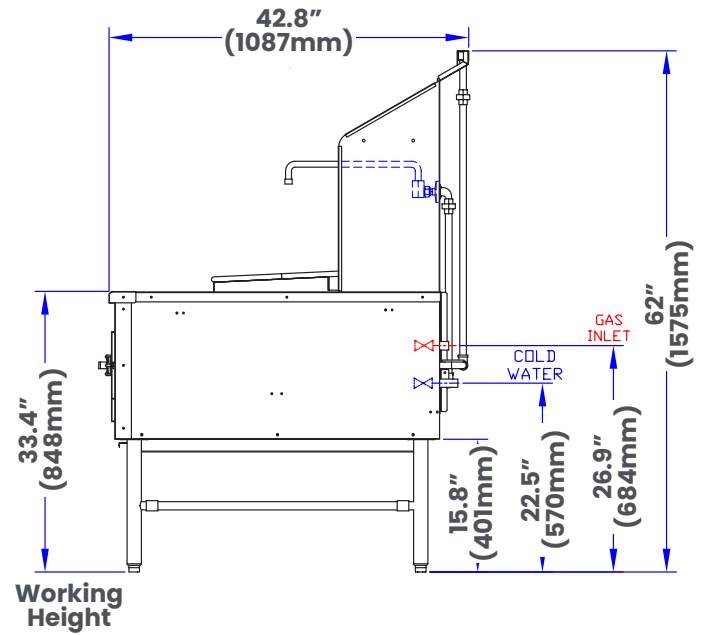
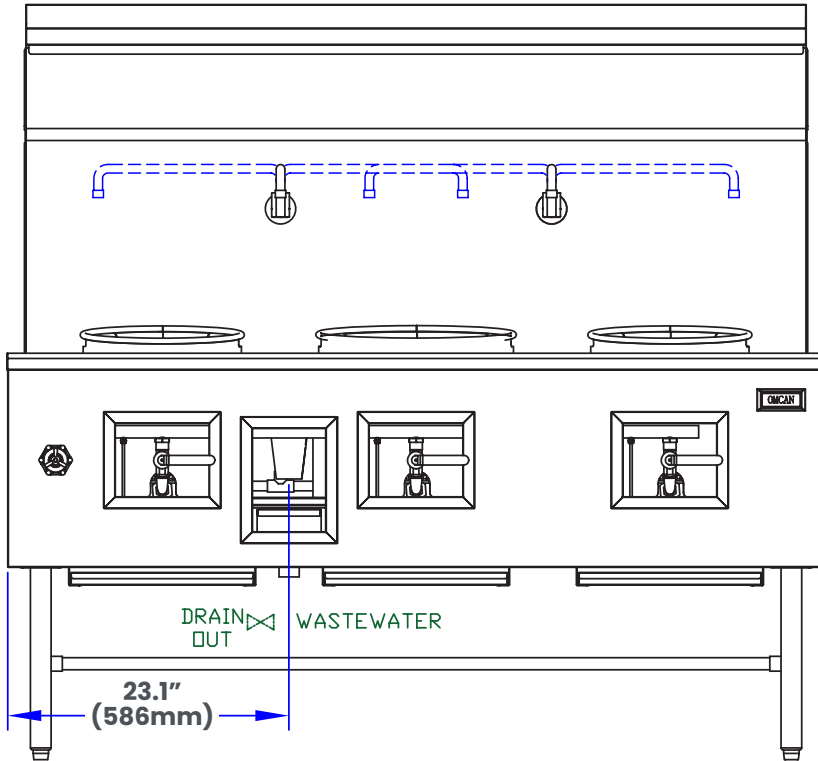

TECHNICAL DRAWING (49042)

