



SERVING THE FOOD INDUSTRY SINCE 1951

## 47" 8+4 Tub Capacity Ice Cream Dipping Freezers With Flat Sneeze Guard

ITEM: 50120  
MODEL: FR-CN-0047



### Its Small Size Makes This an Ideal Freezer for Places With Limited Space.

Spacious glass display ice cream freezer crafted with enduring quality. Small size to capacity ratio optimal for locations with limited space and maximum number of displayed flavours.

#### FEATURES:

- **High Capacity**  
Displays 8 and stores 4 three gallon tubs of ice cream
- **Casters**  
4 Casters under the unit allows easy relocation
- **Space Efficient**  
8 Tub capacity at only 47" wide allows efficient use of limited space to display the maximum number of flavours
- **Easy Access**  
Equipped with sliding doors and locks

Telephone: 1-800-465-0234

Fax: (905) 607-0234

Email: sales@omcan.com

Website: www.omcan.com



Authorized Dealer

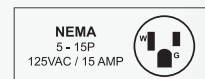
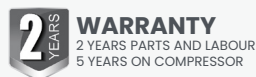

## TECHNICAL SPECIFICATION

Item	50120
Model	FR-CN-0047
Capacity	8+4 (3 Gallon Tubs)
Shelf Loading Capacity	88 lb. (40 kg.)
Temperature Range	-26 to -11.6 °C (-15 to 11°F)
Number of Doors	1 Sliding Door
Number of Shelves	4
Power	438W
Electrical	115V / 60 Hz / 1 Ph
Amps	5.16A
Net Dimensions	47.2" x 27.7" x 51.4" (1200 x 705 x 1305 mm)
Gross Dimensions	51.4" x 32.1" x 54.5" (1306 x 817 x 1385 mm)
Net Weight	239.8 lb. (108.7 kg.)
Gross Weight	349.8 lb. (158.7 kg.)

## TECHNICAL DRAWING

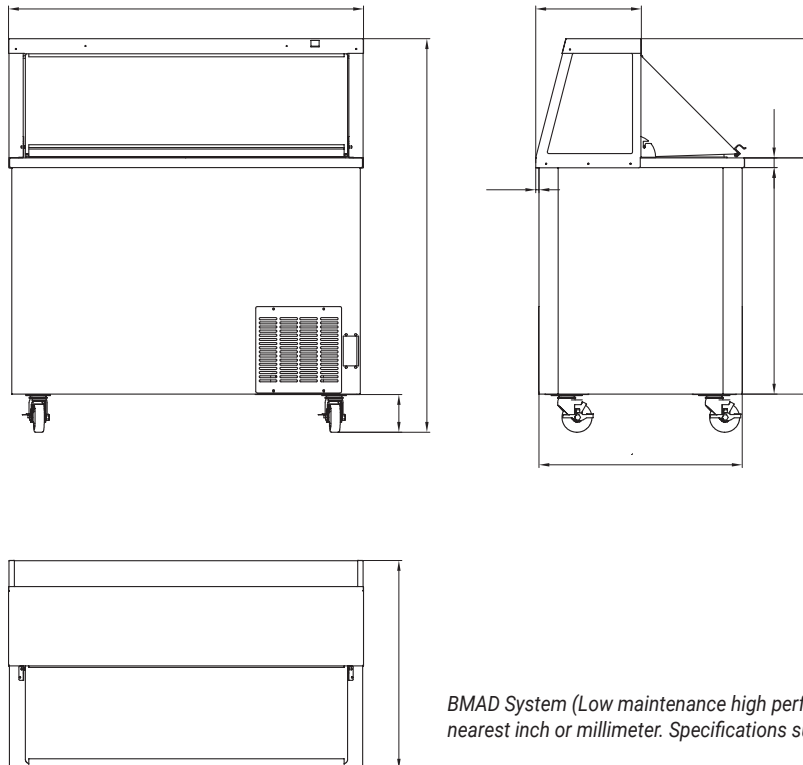

*BMAD System (Low maintenance high performance). Dimensions rounded up to the nearest inch or millimeter. Specifications subject to change without notice.*