



Hydraulic Cheese Graters

Models GR-IT-1500-H, 1500-CR1200, 0300-H 0300-CR800

Items 45403, 47931, 45404, 47930

Instruction Manual



Revised - 12/29/2023

Toll Free: 1-800-465-0234
Fax: 905-607-0234
Email: service@omcan.com
www.omcan.com



Table of Contents

Model GR-IT-1500-H / Model GR-IT-1500-CR1200
Model GR-IT-0300-H / Model GR-IT-0300-CR800

Section	Page
General Information -----	3 - 4
Safety and Warranty -----	4 - 9
Technical Specifications -----	9
Installation -----	10 - 13
Operation -----	13
Maintenance -----	14 - 16
Troubleshooting -----	17 - 18
Parts Breakdown -----	19 - 32
Notes -----	33 - 34
Warranty Registration -----	35



General Information

Omcan Manufacturing and Distributing Company Inc., Food Machinery of America, Inc. dba Omcan and Omcan Inc. are not responsible for any harm or injury caused due to any person's improper or negligent use of this equipment. The product shall only be operated by someone over the age of 18, of sound mind, and not under the influence of any drugs or alcohol, who has been trained in the correct operation of this machine, and is wearing authorized, proper safety clothing. Any modification to the machine voids any warranty, and may cause harm to individuals using the machine or in the vicinity of the machine while in operation.

CHECK PACKAGE UPON ARRIVAL

Upon receipt of an Omcan shipment please inspect for external damage. If no damage is evident on the external packaging, open carton to ensure all ordered items are within the box, and there is no concealed damage to the machine. If the package has suffered rough handling, bumps or damage (visible or concealed), please note it on the bill of lading before accepting the delivery and contact Omcan within 24 hours, so we may initiate a claim with the carrier. A detailed report on the extent of the damage caused to the machine must be filled out within three days, from the delivery date shown in the shipping documents. Omcan has no recourse for damaged products that were shipped collect or third party.

Before operating any equipment, always read and familiarize yourself with all operation and safety instructions.

Omcan would like to thank you for purchasing this machine. It's of the utmost importance to save these instructions for future reference. Also save the original box and packaging for shipping the equipment if servicing or returning of the machine is required.

Omcan Fabrication et distribution Compañie Limité et Food Machinery d'Amérique, dba Omcan et Omcan Inc. ne sont pas responsables de tout dommage ou blessure causé du fait que toute personne ait utilisé cet équipement de façon irrégulière. Le produit ne doit être exploité que par quelqu'un de plus de 18 ans, saine d'esprit, et pas sous l'influence d'une drogue ou d'alcool, qui a été formé pour utiliser cette machine correctement, et est vêtu de vêtements de sécurité approprié. Toute modification de la machine annule toute garantie, et peut causer un préjudice à des personnes utilisant la machine ou des personnes à proximité de la machine pendant son fonctionnement.

VÉRIFIEZ LE COLIS DÈS RÉCEPTION

Dès réception d'une expédition d'Omcan veuillez inspecter pour dommages externes. Si aucun dommage n'est visible sur l'emballage externe, ouvrez le carton afin de s'assurer que tous les éléments commandés sont dans la boîte, et il n'y a aucun dommage dissimulé à la machine. Si le colis n'a subi aucune mauvaises manipulations, de bosses ou de dommages (visible ou cachée), notez-le sur le bond de livraison avant d'accepter la livraison et contactez Omcan dans les 24 heures qui suivent, pour que nous puissions engager une réclamation auprès du transporteur. Un rapport détaillé sur l'étendue des dommages causés à la machine doit être rempli dans un délai de trois jours, à compter de la date de livraison indiquée dans les documents d'expédition. Omcan n'a aucun droit de recours pour les produits endommagés qui ont été expédiés ou cueilli par un tiers transporteur.

General Information

Avant d'utiliser n'importe quel équipement, toujours lire et vous familiariser avec toutes les opérations et les consignes de sécurité.

Omcan voudrais vous remercier d'avoir choisi cette machine. Il est primordial de conserver ces instructions pour une référence ultérieure. Également conservez la boîte originale et l'emballage pour l'expédition de l'équipement si l'entretien ou le retour de la machine est nécessaire.

Omcan Empresa De Fabricacion Y Distribucion Inc. Y Maquinaria De Alimentos De America, Inc. dba Omcan y Omcan Inc. no son responsables de ningun daño o perjuicio causado por cualquier persona inadecuada o el uso descuidado de este equipo. El producto solo podra ser operado por una persona mayor de 18 años, en su sano juicio y no bajo alguna influencia de droga o alcohol, y que este ha sido entrenado en el correcto funcionamiento de esta máquina, y ésta usando ropa apropiada y autorizada. Cualquier modificación a la máquina anula la garantía y puede causar daños a las personas usando la máquina mientras esta en el funcionamiento.

REVISE EL PAQUETE A SU LLEGADA

Tras la recepcion de un envio Omcan favor inspeccionar daños externos. Si no hay daños evidentes en el empaque exterior, Habra el carton para asegurarse que todos los articulos solicitados estén dentro de la caja y no encuentre daños ocultos en la máquina. Si el paquete ha sufrido un manejo de poco cuidado, golpes o daños (visible o oculto) por favor anote en la factura antes de aceptar la entrega y contacte Omcan dentro de las 24 horas, de modo que podamos iniciar una reclamación con la compañía. Un informe detallado sobre los daños causados a la máquina debe ser llenado en el plazo de tres días, desde la fecha de entrega que se muestra en los documentos de envío. Omcan no tiene ningun recurso por productos dañados que se enviaron a recoger por terceros.

Antes de utilizar cualquier equipo, siempre lea y familiarizarse con todas las instrucciones de funcionamiento y seguridad.

Omcan le gustaría darle las gracias por la compra de esta máquina. Es de la mayor importancia para salvar estas instrucciones para futuras consultas. Además, guarda la caja original y el embalaje para el envío del equipo si servicio técnico o devolución de la máquina que se requiere.

Safety and Warranty

The purpose of these instructions is to provide the necessary information regarding the correct use of the machine and in particular the precautions to be taken for safety reasons. Inside the manual, the operator will find the necessary instructions and/or references regarding:

- Reference documents.
- Correct installation.
- Hazards present and relative notes and warnings.
- Description of the safety measures adopted.

Safety and Warranty

- Safety information necessary to make adjustments during setting and start-up phases.
- The correct scheduled maintenance with special reference to safety devices.
- Compliance with the safety and accident prevention regulations in the workplace.
- Reference to control circuit diagrams (electrical and hydraulic).

Only use the machine after carefully reading the present instructions for use.

The manufacturer reserves the right to carry out changes without notice and without incurring any penalty provided that the main technical and safety characteristics remain the same. On delivery make sure that the equipment has not been damaged during transport and that no accessories are missing. Any complaints will be accepted only in writing within eight days from the delivery date.

KEEPING THE INSTRUCTIONS FOR USE

The instructions for use and the relevant documentation must be kept in a suitable place close to the production line and made available to the operators using the machinery. The instructions for use and the documentation attached (wiring diagrams, pneumatic diagrams, instructions for use of individual components, etc.) are to be considered as an integral part of the machine's instructions for use, therefore:

- They must be kept in a safe place.
- For safety reasons they must be kept up to date and report any significant changes made on the machine.

Before carrying out any maintenance operation, read the instructions for use and the relevant documentation when necessary. If in doubt contact an authorised technician.

INTENDED AND IMPROPER USE OF THE MACHINE

This GRATER is to be used for grating cheese on the type Parmesan/Grana Padano/Trentingrana. The manufacturer does not guarantee correct functioning if you use other type of cheese. The machine is meant for use in environments and for applications consistent with its design. Any misuse of the machine is prohibited. The manufacturer is not to be held liable for any errors contained in these instructions or for any injury due to or arising from the improper use of the machine.

Using the machine for different purposes or with materials other than those intended shall be considered improper.

GENERAL SAFETY REGULATIONS

Accidents may be caused by: negligence, misuse of machine parts, instinctive reactions in the event of malfunction or failure. The machine is equipped with safety guards that take into account the possible causes of injury due to normal negligence or predictable misuse. In particular, the following possible behaviors have been taken into consideration:

- Predictable improper behavior due to normal negligence and not due to the deliberate intention of using the machine incorrectly.
- A person's instinctive reaction during use in case of malfunction or breakdown.
- The behavior that results from the easiest course of action when performing a task.

Operations that are not part of the normal conditions of use should in all cases be carried out by qualified and authorised personnel who are aware of the hazards, the different operating modes, safe operating procedures

Safety and Warranty

and have received the necessary training.

Warning, danger of mechanical moving parts, particularly:

- Crushing caused by the movements of the pusher and the panel that are moved by pneumatic cylinders.
- Abrasion due to the grating belts covering the surface of the drums.
- Conveying and dragging caused by the grating belts covering the surface of the drums compared to the nearby fixed parts.

Before proceeding with the start-up, use and maintenance operations of the machine, read this manual carefully and thoroughly make sure that any unsafe condition has been properly removed or reduced as much as possible. Check that all the safety guards mentioned in these instructions are actually present and functioning.

Never carry out any cleaning, lubrication or maintenance operations when the machine is in motion or powered.

Do not wear rings, watches, jewelry, dangling or unbuttoned clothing such as ties, torn clothing, scarves, unbuttoned or unzipped jackets that can be caught in the moving parts of the machine.

Before starting the machine the operator must verify the presence of any visible faults on the guards or safety devices:

- If necessary, inform the maintenance manager.
- Refrain from carrying out any operations for which authorisation and training has not been previously given.

Beware of hazards due to direct contact!

Operations on the electrical parts of the machine must only be carried out by qualified technical personnel with the necessary electrical engineering skills, after referring to the wiring diagram and the necessary conditions in order to avoid electrocution.

Beware of hazards due to indirect contact!

Connection must be earthed and line protection coordination are to be ensured in case of indirect contact in accordance with the IEC 64-8 regulation.

PROTECTIONS AND SAFETY MEASURES

Below is a guideline on the safety guards adopted in order to eliminate or at least reduce the dangers present as much as possible. Please note that safety measures are not always in themselves sufficient to completely guarantee against possible injury; adequate information and training for employees and compliance with the current safety regulations are also necessary.

It is absolutely forbidden to operate the machine without the guards and safety devices indicated in these instructions for use.

Safety and Warranty

GUARDS

The guards can consist of a part of the machine specifically used to provide protection through a physical barrier. Depending on its construction, a guard can be called a casing, cover, screen, etc.

FIXED GUARDS

The fixed guards are considered as such when they feature fixing elements which can only be removed by using a tool. The following are considered fixed guards:

- The driving belt's protection casing placed between the motor and the grater's pulley.

Before removing the fixed guard, the protected areas must be secured by switching off the power from the control panels to stop any movement. Replace the guards that have been removed before leaving the workplace or before resuming work.

INTERLOCKING GUARDS

The interlocking guards are equipped with position sensors that detect whether the guard is open/close and cause dangerous moving parts to stop (interlocking device) when the guards are opened. Opening the guards prevents the dangerous moving parts from restarting. The following are considered interlocking guards:

1. The hinged cover of the loading hopper.
2. The grater's casing (removable).
3. The discharging hopper (on sliding guides).
 - The movable guards 1 - 2 - 3 are equipped with an interlock device consisting of a safety magnetic sensor (with control unit located in the control panel).

Do not remove or force the interlocking guards' position sensors as this may cause the safety devices to malfunction leading to dangerous situations.

Regularly check the correct functioning of the interlocking devices.

EMERGENCY STOP

Emergency stops are located as below:

- On the machine's electrical board.
- On the control panel (upper area) as an emergency stop push button.

The emergency stop push button is equipped with a self-retaining device (once triggered it remains locked in the open circuit position) that needs to be deliberately reset by an operator after being pushed. Pushing the emergency button will stop all the machine's moving parts.

ELECTRICAL EQUIPMENT – SAFETY MEASURES

The electrical equipment is made in accordance with the regulations specified in IEC EN 60204-1 standards, both with regards to the danger of electrocution (direct - indirect contacts), and to the breakdown of the control circuits that may cause hazardous conditions (e.g. malfunction of a safety device). The main safety measures are listed below:

Safety and Warranty

- **PROTECTION AGAINST DIRECT CONTACT:** the casings have at least an IP 2X - IP 4X protection level. Opening a casing (doors, lids, etc. ...) containing live parts is possible by means of a key (only for qualified or trained operators).
- **PROTECTION AGAINST INDIRECT CONTACT:** the masses are connected to the protection circuit and the automatic shutdown of the power supply is guaranteed in case of failure.
- **PROTECTION AGAINST AUTOMATIC RESTART AFTER SHUTDOWN AND RESETTING THE POWER SUPPLY:** minimum voltage devices are provided whenever the automatic restart may cause a hazardous condition (interruptions in the power supply).
- **MANUAL DISCONNECTION:** manual disconnecting devices (switches) are present on the control panel allowing to disconnect the entire electrical equipment of a line from the power supply for cleaning, maintenance and in case of long service interruptions.

Operations on the electrical parts of the machine must only be carried out by technical personnel with the necessary electrical engineering skills.

BEFORE SWITCHING ON THE POWER, CHECK THAT:

- The various parts have been mechanically assembled in an appropriate manner and are stable.
- The electrical connections are correct and that power meets the specified limits (e.g. voltage, frequency, pressure).
- The other (air) systems are properly connected and are within the specified limits.
- The peripheral equipment is connected properly.
- The guards and safety devices are fitted.
- The physical environment is as indicated (for example: correct lighting and noise levels, temperature, humidity, atmospheric contaminants).

AFTER POWER HAS BEEN SWITCHED ON, CHECK THAT:

- Start, stop and the control devices function as required.
- Circuits and emergency stop and safety stop devices are functioning.
- It is possible to disconnect and isolate the external power sources.
- Guards and interlocking devices function as required.
- All the safety devices (fixed enclosures, immaterial barriers, fixed guards) are positioned correctly and are functioning.

TRAINING THE PERSONNEL

The user must ensure that personnel using the machine is adequately trained and has the skills in carrying out their duties safely. Training must include at least:

- Identifying possible hazards.
- Acknowledgement of the guards and safety measures.
- A clear definition of the tasks assigned.
- Identifying and explaining all the control devices and all their functions used when carrying out the tasks assigned.
- Identifying the hazards associated with the assigned tasks.

The personnel operating with the machine must be informed on the specific risks and receive adequate



Safety and Warranty

basic training on safety regulations.

RESIDENTIAL USERS: vendor assumes no liability for parts or labor coverage for component failure or other damages resulting from installation in non-commercial or residential applications. The right is reserved to deny shipment for residential usage; if this occurs, you will be notified as soon as possible.

1 YEAR PARTS AND LABOUR WARRANTY

Within the warranty period, contact Omcan Inc. at 1-800-465-0234 to schedule an Omcan authorized service technician to repair the equipment locally.

Unauthorized maintenance will void the warranty. Warranty covers electrical and part failures, not improper use.

Please see <https://omcan.com/disclaimer> for complete info.

WARNING:

The packaging components (cardboard, polyethylene, and others) are classified as normal solid urban waste and can therefore be disposed of without difficulty.

In any case, for suitable recycling, we suggest disposing of the products separately (differentiated waste) according to the current norms.

DO NOT DISCARD ANY PACKAGING MATERIALS IN THE ENVIRONMENT!

Technical Specifications

Model	GR-IT-1500-H	GR-IT-1500CR1200	GR-IT-0300-H	GR-IT-0300-CR800
Horsepower	20HP 14.9 kW - Self-Braking Motor		5.5HP 4.1 kW Self-Braking Motor	
Electrical	208V / 60Hz / 3			
Production Rate/HR	2646 - 3307 lbs. / 1200 - 1500 kgs.		440.9 - 661 lbs. / 200 - 300 kgs.	
Weight	1874 lbs. / 850 kgs.	2182 lbs. / 990 kgs.	661 lbs. / 380 kgs.	859 lbs. / 470 kgs.
Dimensions	98.6" x 44" x 53" / 2505 x 1120 x 1350mm		76.7" x 31.5" x 47" / 1950 x 800 x 1200mm	
Vibrating Screen Dimensions	N/A	47" x 55.6" x 35" 1205 x 1411 x 894mm	N/A	33.6" x 41" x 32" 885 x 1035 x 815mm
Item Number	45403	47931	45404	47930

Installation

TRANSPORT

Transport shall be carried out by qualified personnel so as to avoid any damage to the machine and any of its components. In particular:

- All the guards, covers and doors must be properly closed and secured.
- Use a forklift or transpallet with sufficiently long forks and loading capacity.
- If the forks are not long enough, use two forklifts positioned one facing the other.
- Insert the appropriate equipment supplied with the machine next to the feet which enables the use of the forks.

The machine should be transported on a flat and solid floor only, free of unevenness.

INSTALLATION

Installation must be carried out by qualified personnel. Connection to the power supply must be carried out in accordance with the IEC standards and taking into account the necessary measures in order to avoid the dangers of indirect contact and overcurrent. Once the GRATER is in place, it must be properly levelled by adjusting the feet's threaded rods. This must be done by means of an optical level. Please note that when the grater leaves our warehouse it has already been levelled.

Make sure the GRATER is placed in a sufficiently lit work area. Check that there is enough space around the machine to move the removable parts and that it is easily accessible for routine and extraordinary maintenance (at least 500 mm of free space besides the dimensions of removable parts).

When installing the machine the space needed by the operators during the normal working process with respect to other existing fixed equipment or structures must be taken into account.

The machine is equipped for the earth-connection of conductive metal masses. The connection must be ensured and carried out correctly in accordance with applicable technical standards. The machine cannot be used if it is not earthed.

Do not loosen any fitting of connection pipes from parts of the machine until all the remaining pressure has been exhausted.

Operations on electrical equipment must only be carried out by qualified technical personnel with the necessary electrical engineering skills, after referring to the wiring diagram and the necessary conditions in order to avoid electrocution.

Installation

POSITIONING THE VIBRATING SCREEN UNDERNEATH THE GRATER



Disk fastened to the unloading hopper which prevents hands reaching hazardous areas



The grater can only be started once the vibrating screen has been correctly positioned underneath the unloading hopper, i.e., fastened to the two support feet of the grater by means of the special fastening devices.

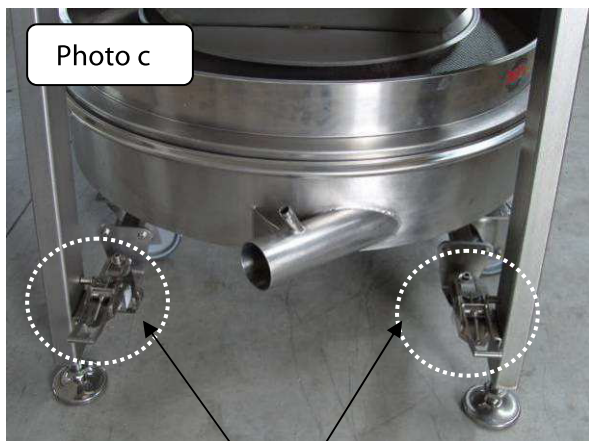

Vibrating screen fastening devices (right and left)

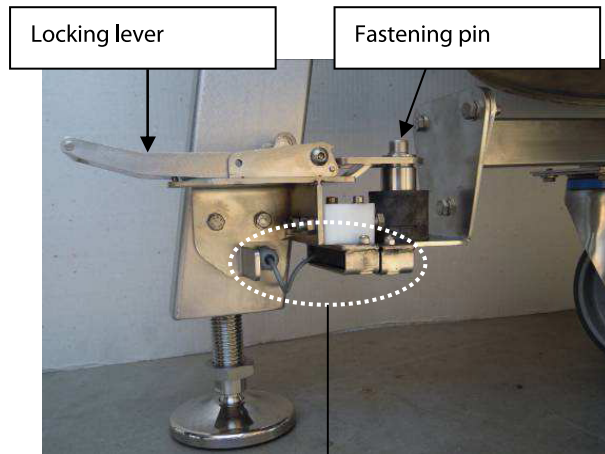

One of the two fastening systems features an interlocking device (proximity sensor of the coded magnetic type) which prevents starting the grater unless the vibrating screen has been correctly positioned.

Never try and start the grater unless the vibrating screen is correctly positioned and fastened (Photo

Installation

c).



Interlocking device with coded magnet sensors of the loading hopper lid

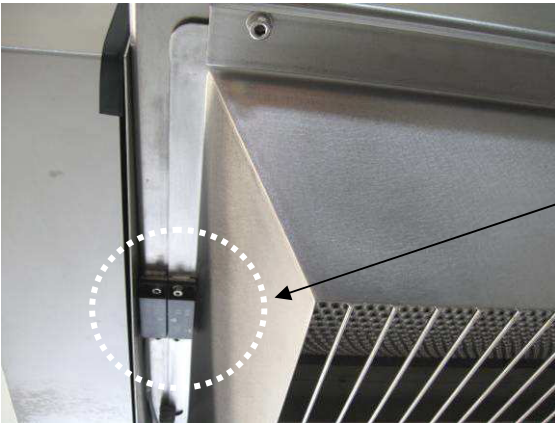

Interlocking device with coded magnet sensors of the discharging hopper lid



Interlocking device with coded magnet sensors of the grater's (removable) casing

The magnet sensors are coded to avoid being inhibited by using a standard magnet.

Installation

The sensors must be replaced with the same type of sensors suitable to perform safety functions.

CONTROL DEVICES

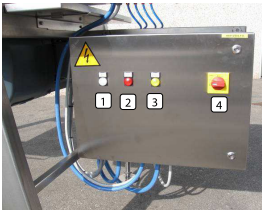

ELECTRICAL BOARD ON THE MACHINE

1. Power on indicator light.
2. Indicator light for motor operation temperature.
3. Indicator light for the correct operation of the magnetic interlocking devices.
4. Main switch/emergency stop.



CONTROL PANEL TOP AREA

1. Stop control.
2. Start control.
3. Thrust pressing device release control.
4. Emergency stop.
5. Pressing device thrust pressure gauge.

Before starting the machine the operator must verify the presence of the guards described in these instructions.

Operation

Check the electrical and pneumatic connections, the pressure in the thrust cylinder (2 bar) and the correct rotational direction of the drum (clockwise, as viewed from the discharging hopper output side). Proceed as follows:

1. Lift the hopper's lid.
2. Introduce the food to be grated.
3. Close the lid.
4. Press the start button (button 2 on the control panel) (grater rotation and pressing device thrust).
5. If necessary the pressing device can be pushed back continuously or in jogs (button 3 on the control panel).

STARTING THE VIBRATING SCREEN

For vibrating screen start-up and operating conditions follow the indications of these operating instructions and the attached manufacturer's specific operating instructions.

The vibrating screen does not present any hazards of a mechanical nature, but it is most important to position it correctly to ensure the safe use of the grater (unloading hopper area).

To start the vibrating screen, keep to the specific manufacturer's attached operating instructions.

Maintenance

Only qualified, specially trained and authorised personnel should carry out maintenance, cleaning and repair jobs.

Before carrying out any operation, the following precautions must be taken:

- Switch off the power on the machine panel via the power disconnecting device.
- Disconnect the machine from the pneumatic supply mains.

At the end of each operation:

- Reset and properly secure all the fixed and/or interlocking guards.

Do not perform any operations without having received specific authorisation and adequate training on the operating procedures as well as being informed about the possible risks.

No cleaning, lubrication or maintenance operations should ever be carried out whilst the grater is operating or powered.

To disconnect the power supply, open the switch located upstream of the flexible power cable or its plug. If a plug is present, disconnect the plug from the socket.

Interventions on the electrical equipment of the machine must only be carried out by technical personnel with specific skills in electrical engineering.

CLEANING THE MACHINE AND ITS COMPONENTS

To keep the grater in perfect working order, regularly clean the machine as described below. The machine should be cleaned externally and internally on a daily basis. For a more effective internal cleaning it is advisable to remove the upper and lower parts and direct a jet of water in to the parts that need descaling. Prior to any cleaning operations, it is necessary to:

- Switch off the power on the machine's panel via the power disconnecting device.
- Disconnect the machine from the pneumatic supply mains.

DAILY CLEANING OPERATIONS

The following parts must be cleaned of any food residue by using food-grade products. Dismantle all the parts that can be removed as shown in the figure below.

- The upper casing covering the grater.
- The product discharging hopper.
- Inner drum area.
- Internal hopper.
- The rear discharge collecting tray.
- Toothed belts.

The substances used for cleaning the machine which may come into contact with food must comply with the food hygiene regulations.

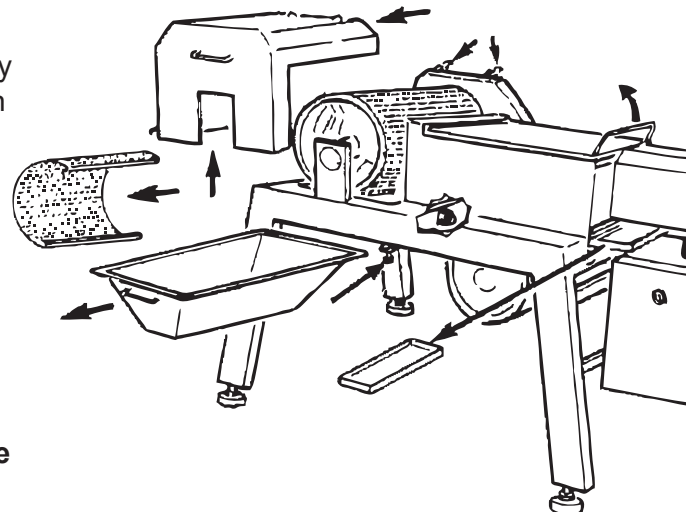

Maintenance

ADJUSTING CLEARANCE BETWEEN THE BLADE AND DRUM

To adjust the clearance between the blade and drum, proceed as follows:

- In the inner part of the base, loosen the screws A by using a 17 hexagonal spanner.
- By using a 27 hexagonal spanner rotate the bushes B which allow the blade to go up or down thereby varying the clearance with the drum.
- Once the desired clearance is obtained, block the screws A.

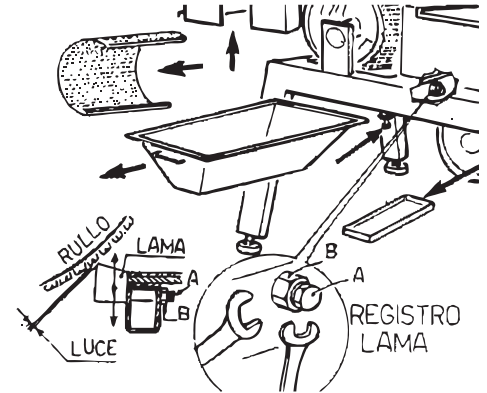

IMPORTANT: manually rotate the drum at least once before starting the machine.

ADJUSTMENT AND CALIBRATION

- Adjust the pressure of the thrust cylinder to the work requirements (recommended pressure 1.5 — 2 bar).
- Toothed belts tensioning with slight clearance between them.
- Calibration of the pressure regulator air intake 6 - 8 bar.
- V-belt tensioning (adjusting the motor tie rods).

ROUTINE MAINTENANCE

The routine maintenance operations to be carried out are listed below.

Operation	Frequency
Tensioning or replacement of the drum driving belts.	Monthly
Tensioning or replacement of worn toothed belts.	When necessary
Checking the motor brake pads.	Annually
Checking the indicator lights.	Monthly
Checking all the locking systems (particularly the locking set on the pulley).	Weekly
Checking the correct operation of the mobile guards with interlocking device.	Daily
Cleaning the microswitches with compressed air in the key seat.	Weekly

The guards and safety devices must be regularly inspected and checked to see if they operate correctly.

Before starting the machine and before beginning the work all the movable and fixed guards must be in their locked position.

TOOTHED BELTS REPLACEMENT

To replace the toothed belts, proceed as follows:

1. Release the motor brake by means of the key switch inside the machine control panel.
2. Remove the upper drum cover by releasing the quick-release locks.
3. Align the drum ready to be pulled out, unscrew the tie rod by using a 22 hexagonal spanner until the first

Maintenance

belt is loose.

4. Wear protective gloves and pull out the first belt.
5. Repeat the operation on the second belt.
6. Perform the same operations in the reverse order to reassemble and check the tension of the new toothed belts. The best condition is obtained with minimum clearance between the two belts.
7. Reassemble the cover on the drum and secure it.
8. Engage the motor brake in the locked position.

During this operation care must be taken to avoid crushing and scraping of the hands. Wear protective gloves.

BELT REPLACEMENT - TENSIONING

When replacing or tensioning the belts, proceed as follows:

1. Disconnect the machine from the mains.
2. Remove the securing nuts from the guard (ref. 1 figure on the right).
3. Remove the guard (ref. 2).
4. Loosen the motor fastening nuts (ref. 3).
5. Tighten the screw (ref. 4) to obtain belt tensioning (ref. 5).
6. Once the correct tensioning has been reached, tighten the nuts (ref. 3).
7. Reassemble the guard and secure it using the nuts.

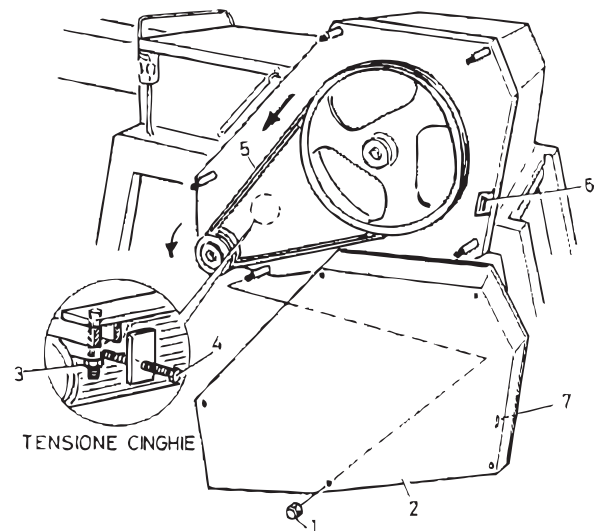

Never carry out any cleaning, lubrication or maintenance operations when the machine is moving or powered.

Troubleshooting

Malfunctions and faults	Cause	Remedy
Machine at a standstill.	No electricity.	Check the connection. Check the main switch on the control panel.
	The movable interlocking guards are open.	Check that guards are completely closed.
	Motor brake release key turned on.	Turn the key in the locking position.
	Emergency button has been pressed.	Release the emergency button.
	Thermal cut-out triggered.	Reset the thermal protection by pressing the button inside the panel.
	Blown fuses in the electrical board.	Replace the fuses with others having the correct amperage.
Cylinders at a standstill.	No air.	Check the pneumatic connection.
Slow cylinders.	Low pressure.	Increase air pressure to 2 bar approx.
	Clogged filters.	Replace the filters in the pneumatic box.
The thrust plate remains forward.	The thrust cylinder does not return in place.	Check the cylinder end-of-stroke sensor.
Drum does not rotate or stops.	Slack driving belt tension or loosened locking set.	Invert the polarity on the electrical board.
Drum rotates in the opposite direction.	Inverted motor electric connection.	Invert the polarity on the electrical board.
Unsatisfactory product.	Worn toothed belts.	Replace the toothed belts.
	High or low thrust pressure.	Calibrate pressure.
Noisy toothed belts.	Slack toothed belts on the drum.	Tighten the tensioning belt tie rods.
The thrust plate does not move forward.	No pressure.	Check the pneumatic connection (min. 2 bar).
Lid does not open.	No pressure.	Check the pneumatic connection.
Motor slowed down.	Brake fuses.	Replace the fuses in the electrical board.
The drum is noisy when empty.	Drum supporting bearings.	Replace the bearings.
The motor is noisy when it stops.	Motor brake.	Check and replace if necessary the motor brake disc.
Too much smoke in the air exhaust pipe.	Pressure regulator not adjusted correctly.	Adjust the screws on the pressure regulator.
Thrust plate moves forward slowly or doesn't move forward, too much air exiting from the vents.	Faulty solenoid valve. Worn cylinder gasket.	Replace the solenoid valve or gaskets.

Troubleshooting

Machine operating when casing or guards are open.	Dirty or broken microswitches.	Clean or replace the microswitches.
---	--------------------------------	-------------------------------------

Parts Breakdown

Model GR-IT-1500-H 45403

Base Unit

Model GR-IT-1500-CR1200 47931

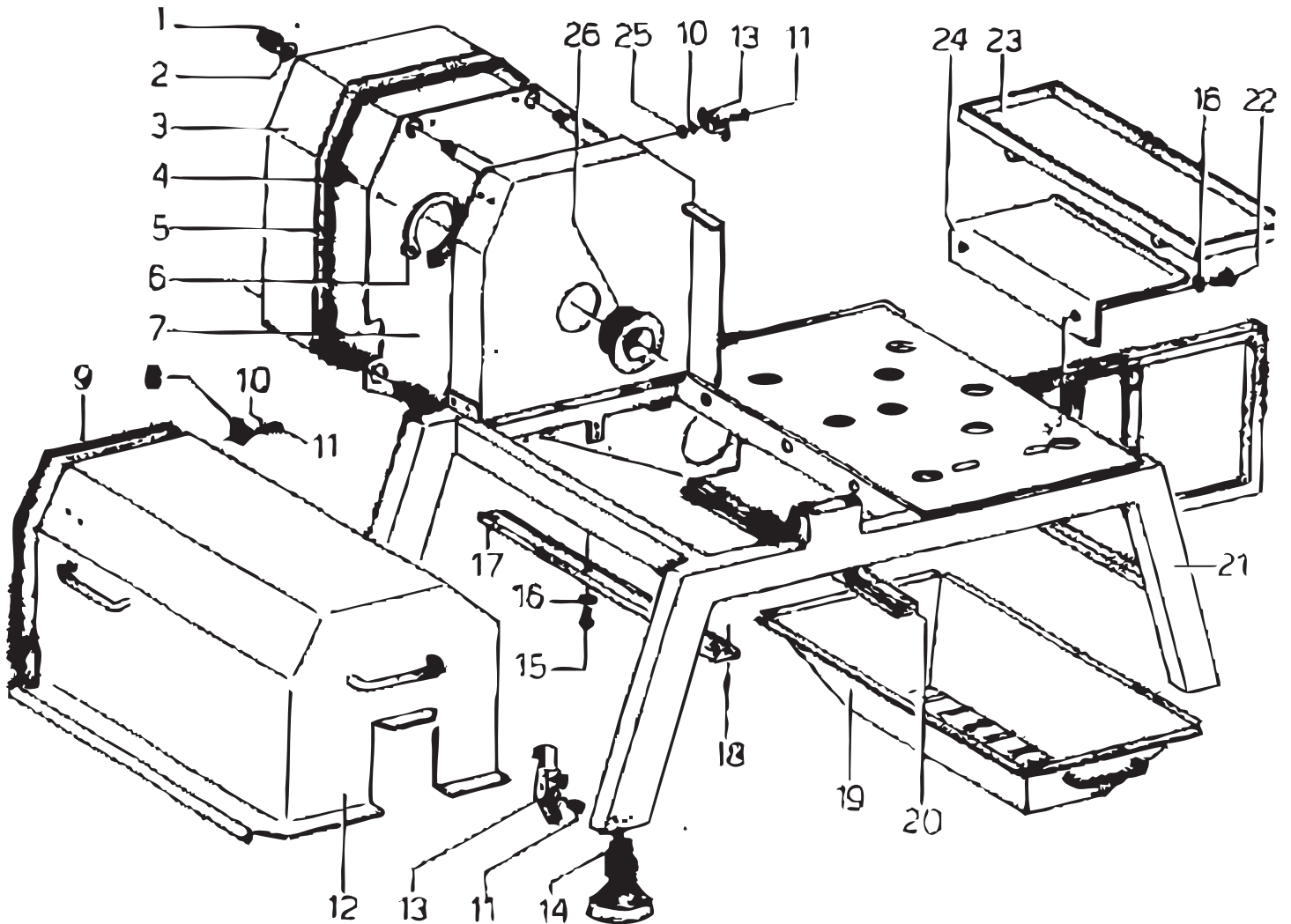

Parts Breakdown

Model GR-IT-1500-H 45403

Drum Unit

Model GR-IT-1500-CR1200 47931

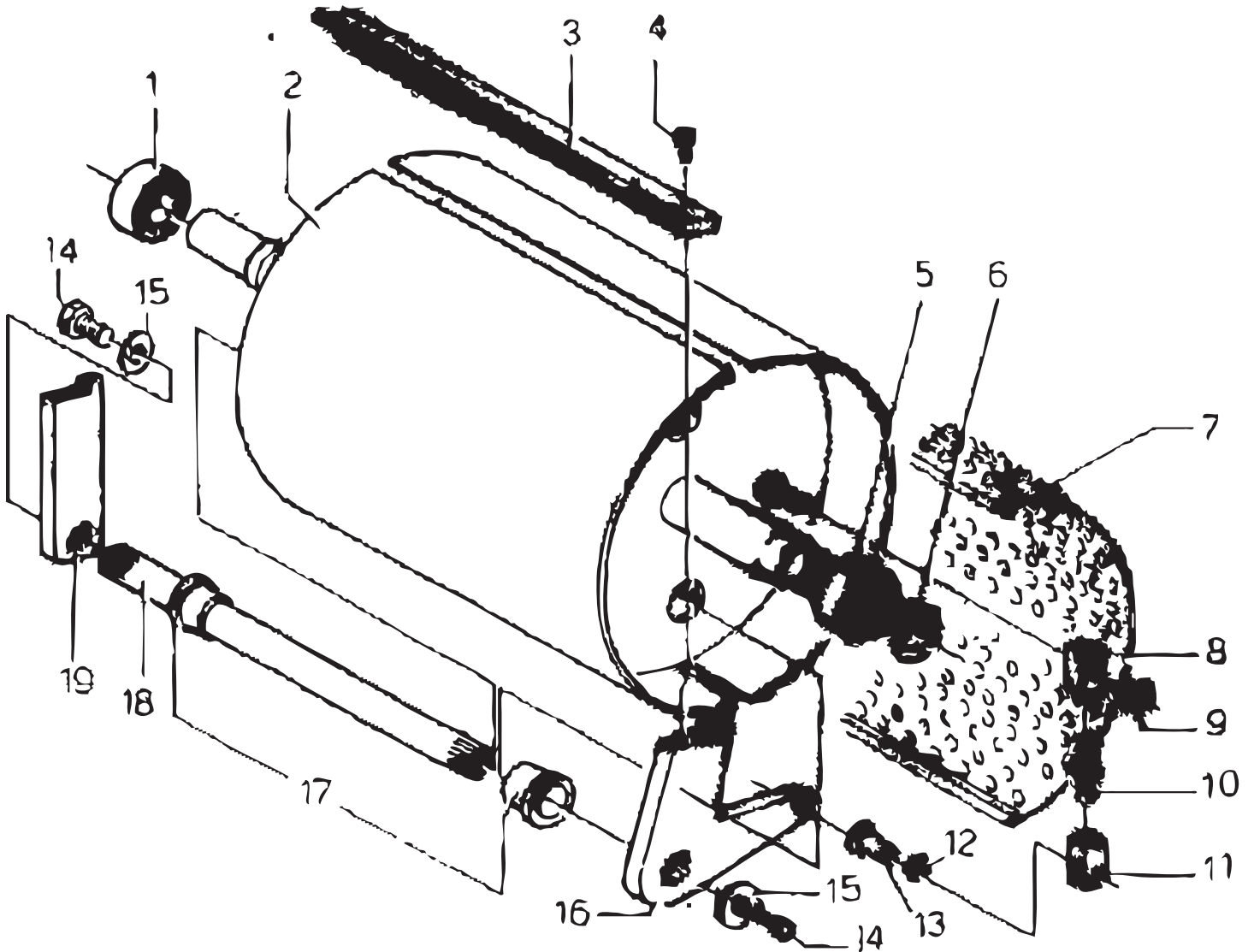

Parts Breakdown

Model GR-IT-1500-H 45403

Drum Driving Unit

Model GR-IT-1500-CR1200 47931

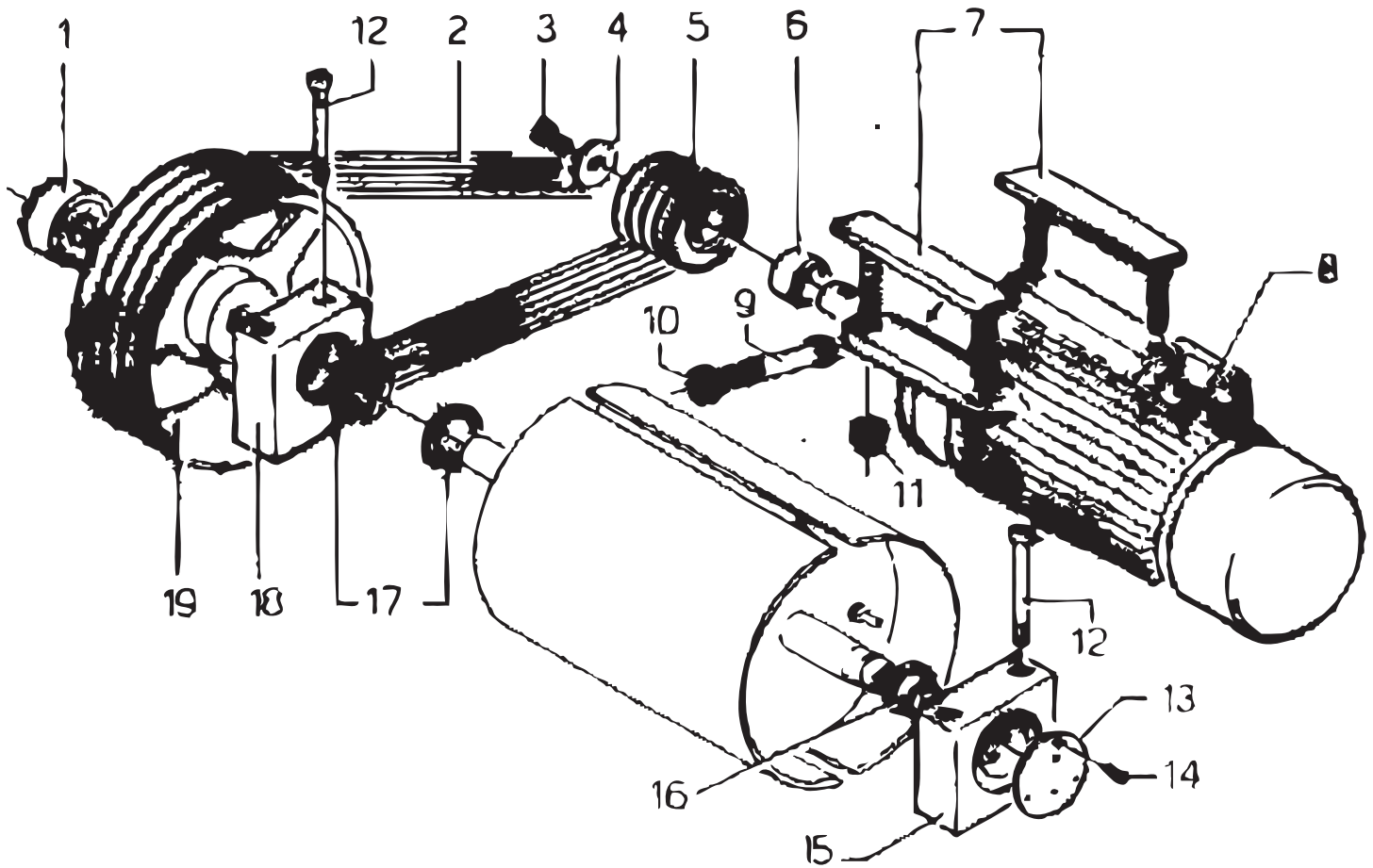

Parts Breakdown

Model GR-IT-1500-H 45403
 Model GR-IT-1500-CR1200 47931

Loading Hopper Unit

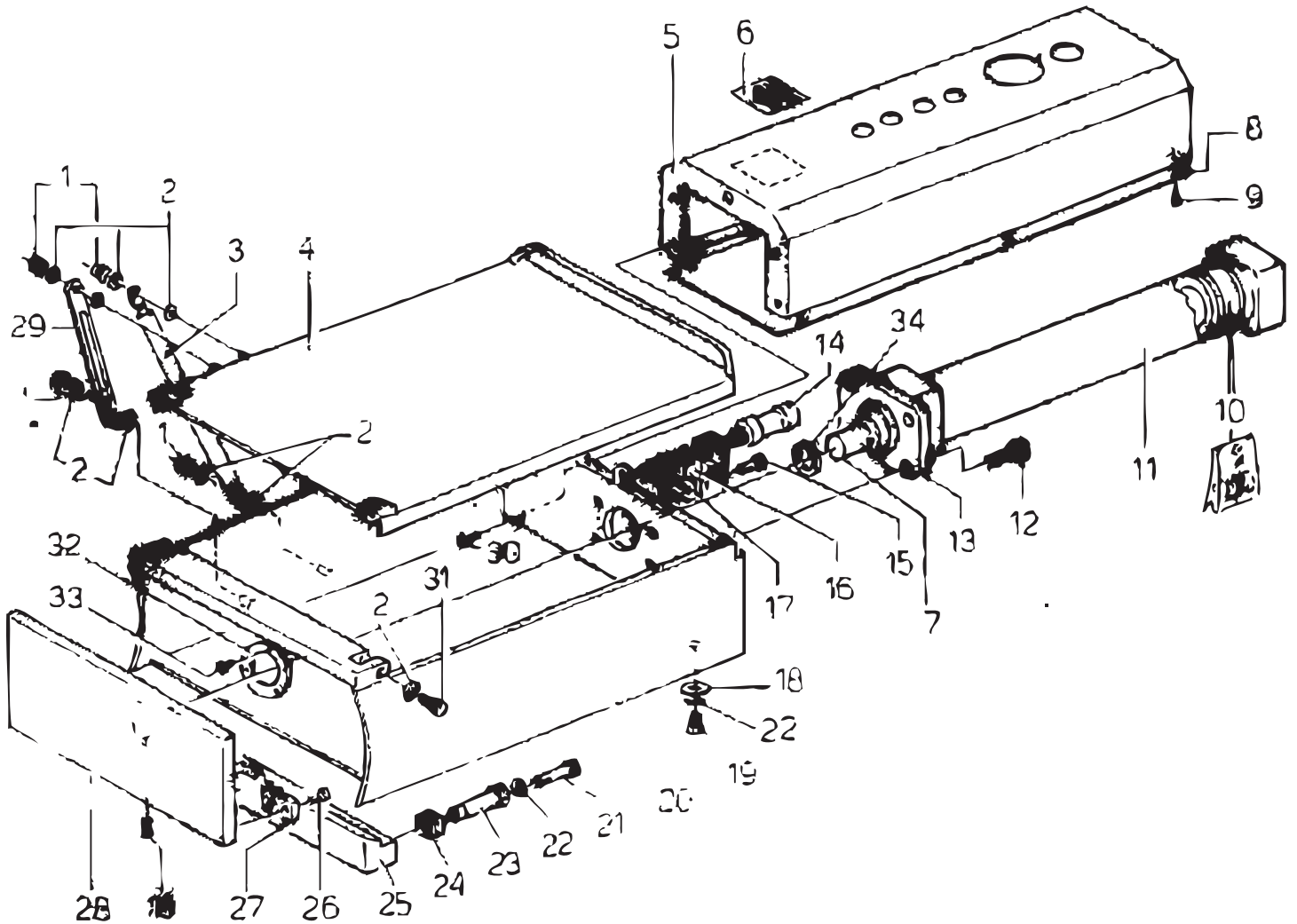



Parts Breakdown

Model GR-IT-1500-H 45403
Model GR-IT-1500-CR1200 47931

Base Unit

Item No.	Description	Position	Item No.	Description	Position	Item No.	Description	Position
AJ706	Blind Nut M10 for 45403, 47931	1	AJ717	Removable Casing for 45403, 47931	12	AJ728	Rail for 45403, 47931	20
AJ707	Flat Washer D.10.5 for 45403, 47931	2	AJ718	Removable Casing for 45403, 47931	12	AJ729	Rail for 45403, 47931	20
AJ708	Belt Casing for 45403, 47931	3	AJ719	Protex Fastener for 45403, 47931	13	AJ730	Bedplate for 45403, 47931	21
AJ709	Cheese-Headed Socket Head Screw M5x16 for 45403, 47931	4	AJ720	Stainless Steel Anti-Slip Articulated Foot for 45403, 47931	14	AJ731	Bedplate for 45403, 47931	21
AJ710	Gasket for 45403, 47931	5	AJ721	Hex. Head Screw M8x20 for 45403, 47931	15	AJ732	Hex. Head Screw M6x10 for 45403, 47931	22
AJ711	Retaining Ring for Shaft D.80 for 45403, 47931	6	AJ722	Elastic Washer A 6.4 for 45403, 47931	16	AJ733	Collecting Tank for 45403, 47931	23
AJ712	Cover for 45403, 47931	7	AJ723	Rail for 45403, 47931	17	AJ734	Collecting Tank for 45403, 47931	23
AJ713	Protex Stop for 45403, 47931	8	AJ724	Rail for 45403, 47931	17	AJ735	Tank Support for 45403, 47931	24
AJ714	Gasket for 45403, 47931	9	AJ725	Hex. Sock. Headless Screw M8x162 for 45403, 47931	18	AJ736	Self-Locking Nut M4 for 45403, 47931	25
AJ715	Flat Washer D.4.3 for 45403, 47931	10	AJ726	Discharging Hopper for 45403, 47931	19	AJ737	Wall Ring for 45403, 47931	26
AJ716	Cross Head Screw M4x10 for 45403, 47931	11	AJ727	Discharging Hopper for 45403, 47931	19			

Drum Unit

Item No.	Description	Position	Item No.	Description	Position	Item No.	Description	Position
AJ738	Bearing 100x45x36 for 45403, 47931	1	AJ746	Toothed Belt for 45403, 47931	7	AJ754	Hex. Head Screw M8x20 for 45403, 47931	14
AJ739	Drum for 45403, 47931	2	AJ747	Toothed Belt for 45403, 47931	7	AJ755	Washer for 45403, 47931	15
AJ740	Drum for 45403, 47931	2	AJ748	LH Fork M18x1.5 for 45403, 47931	8	AJ756	Front Lever for 45403, 47931	16
AJ741	Strip for 45403, 47931	3	AJ749	Retaining Ring for Shaft D.15 for 45403, 47931	9	AJ757	Bushing for 45403, 47931	17
AJ742	Strip for 45403, 47931	3	AJ750	Tie Rod for 45403, 47931	10	AJ758	Shaft for 45403, 47931	18
AJ743	Cheese-Headed Socket Head Screw M8x20 for 45403, 47931	4	AJ751	RH Fork M18x1.5 for 45403, 47931	11	AJ759	Shaft for 45403, 47931	18
AJ744	Bearing 85x45x23 for 45403, 47931	5	AJ752	Retaining Ring for Shaft D.12 for 45403, 47931	12	AJ760	Rear Lever for 45403, 47931	19
AJ745	Retaining Ring for Shaft D.45 for 45403, 47931	6	AJ753	Pin for 45403, 47931	13			

Parts Breakdown

Model GR-IT-1500-H 45403
Model GR-IT-1500-CR1200 47931

Drum Driving Unit

Item No.	Description	Position	Item No.	Description	Position	Item No.	Description	Position
AJ761	Ring Block Locking Set for 45403, 47931	1	AJ768	Motor Fastening Strip for 45403, 47931	7	AJ775	Flat Head Countersunk Socket Cap Screw M5x10 for 45403, 47931	14
AJ762	V-Belts for 45403, 47931	2	AJ769	Motor Sew HP20 for 45403, 47931	8	AJ776	Bearing Support for 45403, 47931	15
AJ763	Hex. Head Screw M16x40 for 45403, 47931	3	AJ770	Hex. Head Screw M14x70 for 45403, 47931	9	AJ777	Bushing for 45403, 47931	16
AJ764	Washer for 45403, 47931	4	AJ771	Nut EW M14 for 45403, 47931	10	AJ778	Retaining Ring for Hole for 45403, 47931	17
AJ765	4-Groove Pulley B D.112 for 45403, 47931	5	AJ772	Self-Locking Nut EM M14 for 45403, 47931	11	AJ779	Bearing Support for 45403, 47931	18
AJ766	Spacer for 45403, 47931	6	AJ773	Cheese-Headed Socket Head Screw M14x130 for 45403, 47931	12	AJ780	4-Groove Pulley B D.450 for 45403, 47931	19
AJ767	Motor Fastening Strip for 45403, 47931	7	AJ774	Lid for 45403, 47931	13			

Loading Hopper Unit

Item No.	Description	Position	Item No.	Description	Position	Item No.	Description	Position
AJ781	Self-Locking Nut M8 for 45403, 47931	1	AJ793	Flange for Stem for 45403, 47931	13	AJ805	Blade for 45403, 47931	25
AJ782	Flat Washer D.8.4 for 45403, 47931	2	AJ794	ISO 6432 Metalwork Cylinder D.25-C-50 for 45403, 47931	14	AJ806	Blade for 45403, 47931	25
AJ783	Gas Spring Inox 400N C.100 for 45403, 47931	3	AJ743	Cheese-Headed Socket Head Screw M8x20 for 45403, 47931	15	AJ807	Screw M6x40 for 45403, 47931	26
AJ784	Lid for 45403, 47931	4	AJ795	Cylinder Fastening for 45403, 47931	16	AJ808	Slide for 45403, 47931	27
AJ785	Lid for 45403, 47931	4	AJ796	Pin for 45403, 47931	17	AJ809	Pressure Plate for 45403, 47931	28
AJ786	Cylinder Cover for 45403, 47931	5	AJ797	Washer for 45403, 47931	18	AJ810	Pressure Plate for 45403, 47931	28
AJ787	Pictogram for 45403, 47931	6	AJ798	Hex. Head Screw M10x20 for 45403, 47931	19	AJ811	Hopper Lid Stop for 45403, 47931	29
AJ788	Cylinder Stem D.32 for 45403, 47931	7	AJ799	Hopper for 45403, 47931	20	AJ812	Hex. Head Screw M8x30 for 45403, 47931	30
AJ789	Cover for 45403, 47931	8	AJ800	Hopper for 45403, 47931	20	AJ813	Hex. Head Screw M8x50 for 45403, 47931	31
AJ716	Cross Head Screw M4x10 for 45403, 47931	9	AJ801	Hex. Head Screw M10x100 for 45403, 47931	21	AJ814	Gasket Seal for 45403, 47931	32
AJ790	Cylinder Seal Kit D.100-32 for 45403, 47931	10	AJ802	Elastic Washer A 10.5 for 45403, 47931	22	AJ815	Flat Head Countersunk Socket Cap Screw M4x10 for 45403, 47931	33
AJ791	Cylinder for 45403, 47931	11	AJ803	Eccentric Pin for 45403, 47931	23	AJ816	Scraper Seal for 45403, 47931	34
AJ792	Cheese-Headed Socket Head Screw M12x50 for 45403, 47931	12	AJ804	Slide for 45403, 47931	24			

Parts Breakdown

Model GR-IT-0300-H 45404
Model GR-IT-0300-CR800 47930

Base Unit

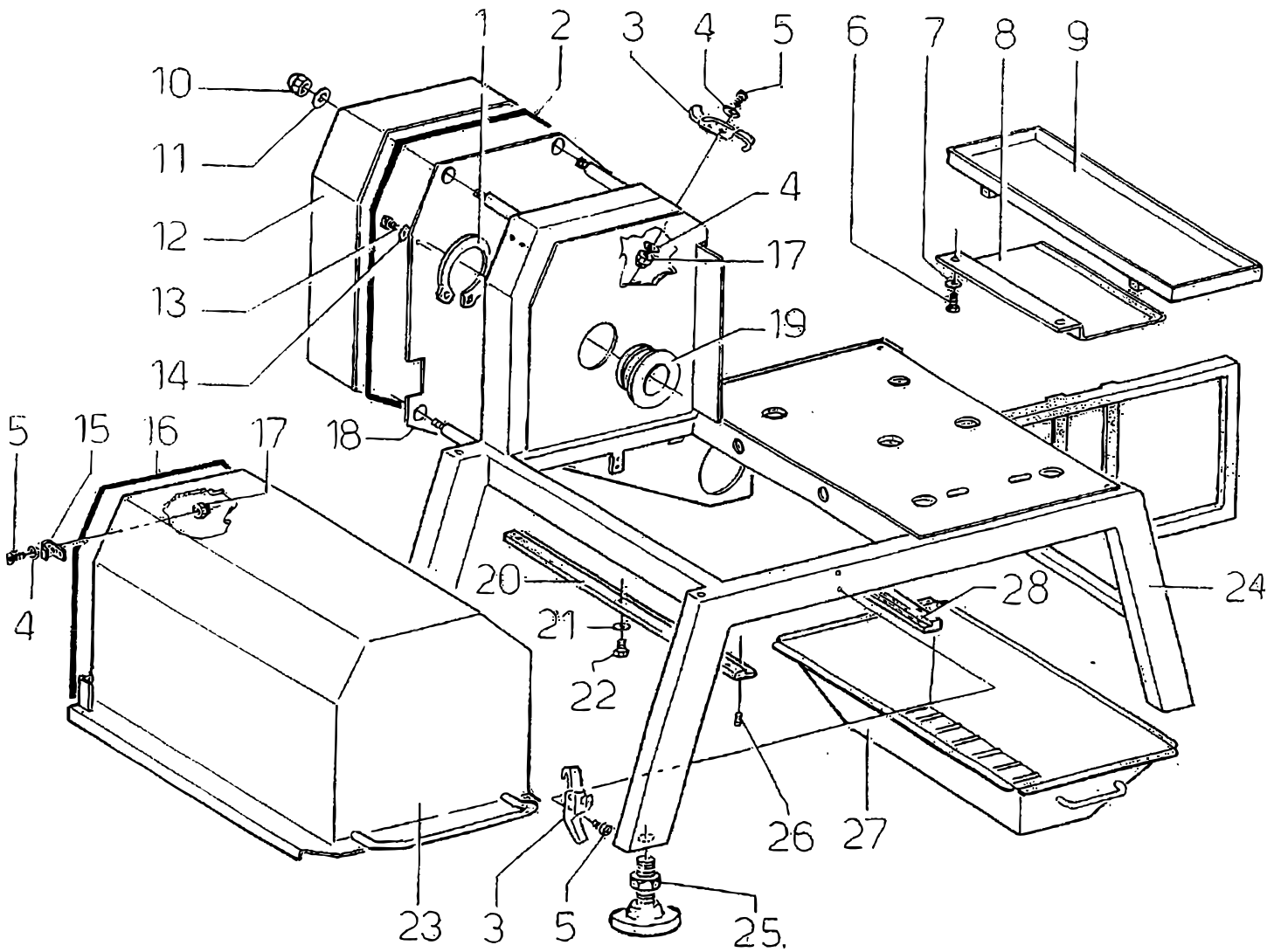

Parts Breakdown

Model GR-IT-0300-H 45404
Model GR-IT-0300-CR800 47930

Loading Hopper Unit

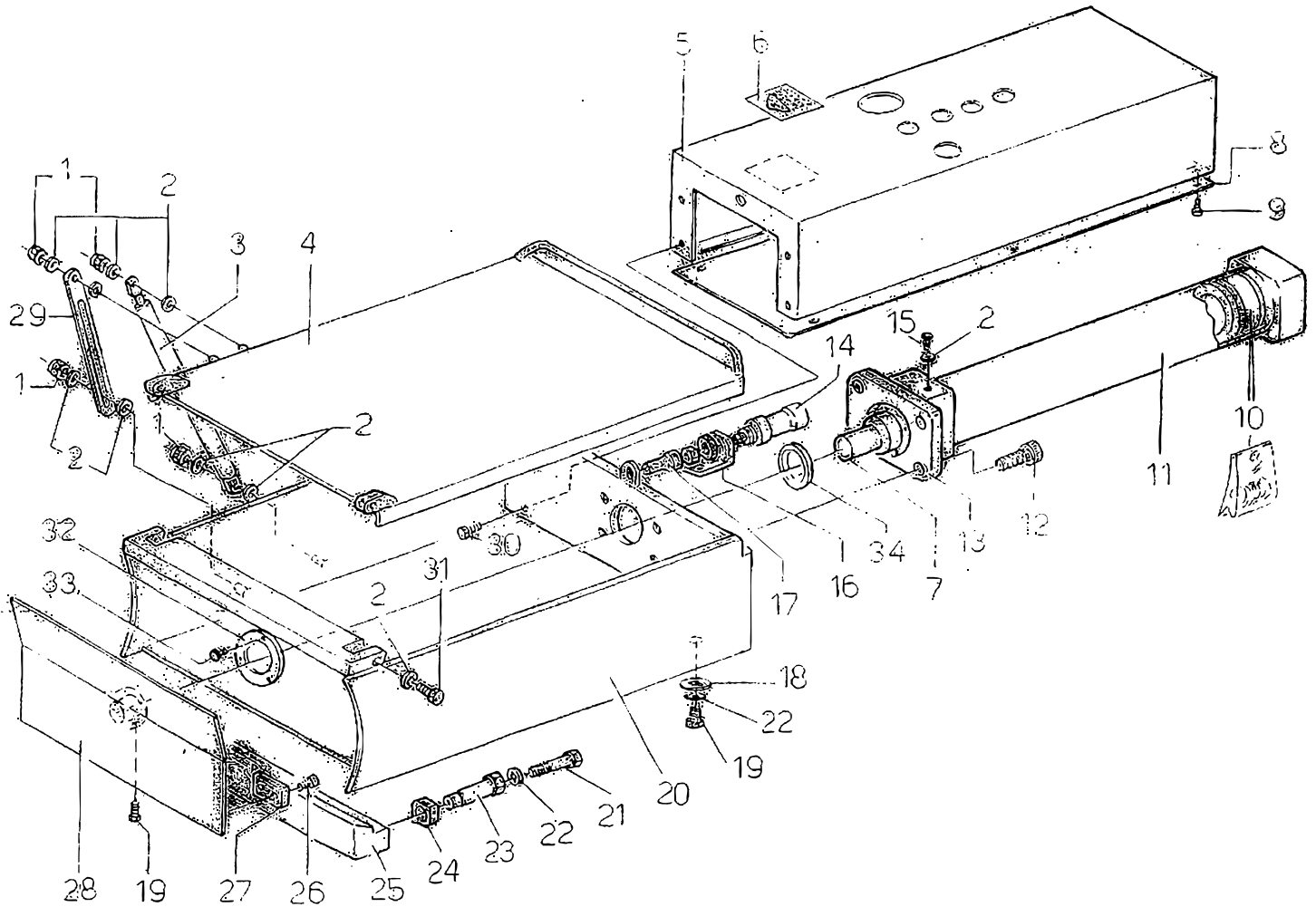

Parts Breakdown

Model GR-IT-0300-H 45404
Model GR-IT-0300-CR800 47930

Base Unit

Item No.	Description	Position	Item No.	Description	Position	Item No.	Description	Position
AJ817	Retaining Ring for Shaft D.90 for 45404, 47930	1	AJ706	Blind Nut M10 for 45404, 47930	10	AJ827	Wall Ring for 45404, 47930	19
AJ818	Gasket for 45404, 47930	2	AJ822	Flat Washer D.10 for 45404, 47930	11	AJ828	Rail for 45404, 47930	20, 28
AJ819	Protex Fastener for 45404, 47930	3	AJ823	Cover for 45404, 47930	12	AJ829	Elastic Washer A 8.4 for 45404, 47930	21
AJ715	Flat Washer D.4.3 for 45404, 47930	4	AJ709	Cheese-Headed Socket Head Screw M5x16 for 45404, 47930	13	AJ721	Hex. Head Screw M8x20 for 45404, 47930	22
AJ716	Cross Head Screw M4x10 for 45404, 47930	5	AJ824	Flat Washer D.5 for 45404, 47930	14	AJ830	Casing for 45404, 47930	23
AJ732	Hex. Head Screw M6x10 for 45404, 47930	6	AJ713	Protex Stop for 45404, 47930	15	AJ831	Base Unit for 45404, 47930	24
AJ722	Elastic Washer A 6.4 for 45404, 47930	7	AJ825	Gasket for 45404, 47930	16	AJ832	Anti-Slip Articulated Foot for 45404, 47930	25
AJ820	Tank Support for 45404, 47930	8	AJ736	Self-Locking Nut M4 for 45404, 47930	17	AJ833	Hex. Sock. Headless Screw M8x16 for 45404, 47930	26
AJ821	Collecting Tank for 45404, 47930	9	AJ826	Cover for 45404, 47930	18	AJ834	Discharging Hopper for 45404, 47930	27

Drum and Drum Driving Unit

Item No.	Description	Position	Item No.	Description	Position	Item No.	Description	Position
AJ835	Hex. Head Screw M10x30 for 45404, 47930	1	AJ843	Self-Locking Nut M10 for 45404, 47930	10	AJ851	Drum for 45404, 47930	19
AJ802	Elastic Washer A 10.5 for 45404, 47930	2	AJ844	Elastic Washer A 13 for 45404, 47930	11	AJ852	Tab A 12x8x50 for 45404, 47930	20
AJ836	Washer for 45404, 47930	3	AJ845	Hex. Head Screw M12x70 for 45404, 47930	12	AJ853	Spacer for 45404, 47930	22
AJ837	Pulley for 45404, 47930	4	AJ846	Grating Belt for 45404, 47930	13	AJ854	Cover for 45404, 47930	23
AJ838	Pulley for 45404, 47930	5	AJ829	Elastic Washer A 8.4 for 45404, 47930	14	AJ855	Bearing 110x60x28 for 45404, 47930	24
AJ839	Spacer for 45404, 47930	6	AJ847	Hex. Head Screw M8x30 for 45404, 47930	15	AJ856	Support for 45404, 47930	25
AJ840	Self-Braking Motor Sew HP 5.5 kW for 45404, 47930	7	AJ848	Hex. Head Screw M6x16 for 45404, 47930	16	AJ857	Bearing 125x70x31 for 45404, 47930	26
AJ841	Tie Rod for 45404, 47930	8	AJ849	Elastic Washer A 6.4 for 45404, 47930	17			
AJ842	Flat Washer D.10 for 45404, 47930	9	AJ850	Hex. Head Screw M12x210 for 45404, 47930	18			

Parts Breakdown

Model GR-IT-0300-H 45404
Model GR-IT-0300-CR800 47930

Loading Hopper Unit

Item No.	Description	Position	Item No.	Description	Position	Item No.	Description	Position
AJ781	Self-Locking Nut M8 for 45404, 47930	1	AJ864	Flange for Stem D.25 for 45404, 47930	13	AJ804	Slide for 45404, 47930	24
AJ782	Flat Washer D.8.4 for 45404, 47930	2	AJ794	ISO 6432 Metalwork Cylinder D.25-C-50 for 45404, 47930	14	AJ806	Blade for 45404, 47930	25
AJ783	Gas Spring Inox 400N C.100 for 45404, 47930	3	AJ743	Cheese-Headed Socket Head Screw M8x20 for 45404, 47930	15	AJ868	Hex. Head Screw M6x40 for 45404, 47930	26
AJ858	Cover for 45404, 47930	4, 8	AJ865	Cylinder Fastening for 45404, 47930	16	AJ808	Slide for 45404, 47930	27
AJ859	Cylinder Cover for 45404, 47930	5	AJ796	Pin for 45404, 47930	17	AJ869	Pressure Plate for 45404, 47930	28
AJ787	Pictogram for 45404, 47930	6	AJ797	Washer for 45404, 47930	18	AJ811	Hopper Lid Stop for 45404, 47930	29
AJ860	Cylinder Stem for 45404, 47930	7	AJ798	Hex. Head Screw M10x20 for 45404, 47930	19	AJ812	Hex. Head Screw M8x30 for 45404, 47930	30
AJ716	Cross Head Screw M4x10 for 45404, 47930	9	AJ866	Hopper for 45404, 47930	20	AJ813	Hex. Head Screw M8x50 for 45404, 47930	31
AJ861	Cylinder Seal Kit D.80-25 for 45404, 47930	10	AJ801	Hex. Head Screw M10x100 for 45404, 47930	21	AJ870	Gasket Seal for 45404, 47930	32
AJ862	Metalwork Cylinder CMW1-080500.A for 45404, 47930	11	AJ867	EL. Washer A 10.5 for 45404, 47930	22	AJ815	Flat Head Countersunk Socket Cap Screw M4x10 for 45404, 47930	33
AJ863	Cheese-Headed Socket Head Screw M12x30 for 45404, 47930	12	AJ803	Eccentric Pin for 45404, 47930	23	AJ871	Stem Scraper Gasket for 45404, 47930	34

Parts Breakdown

Model GR-IT-1500-CR1200 47931
Model GR-IT-0300-CR800 47930

Vibrating Unit

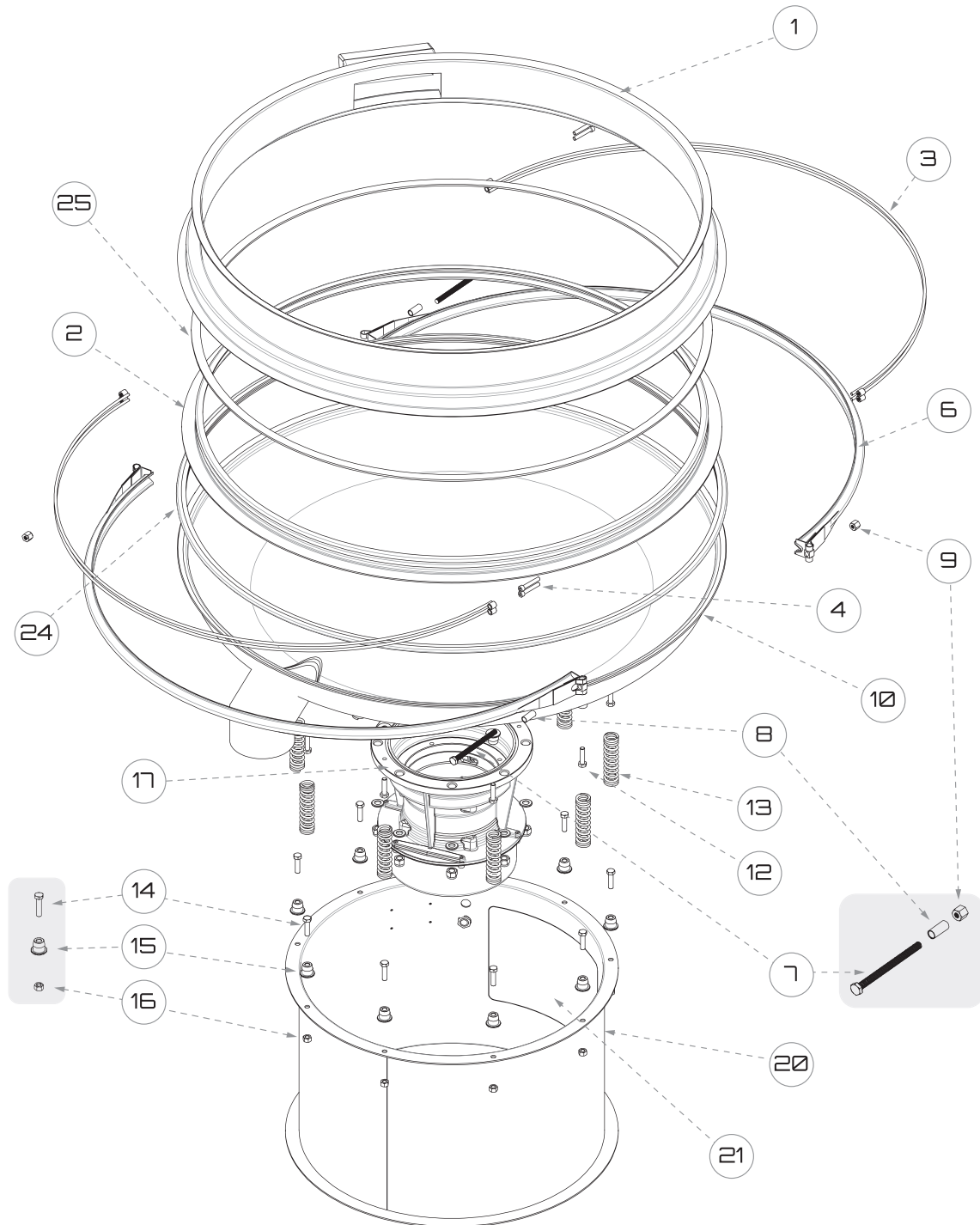

Parts Breakdown

Model GR-IT-1500-CR1200 47931
Model GR-IT-0300-CR800 47930

Vibrating Unit Trolley

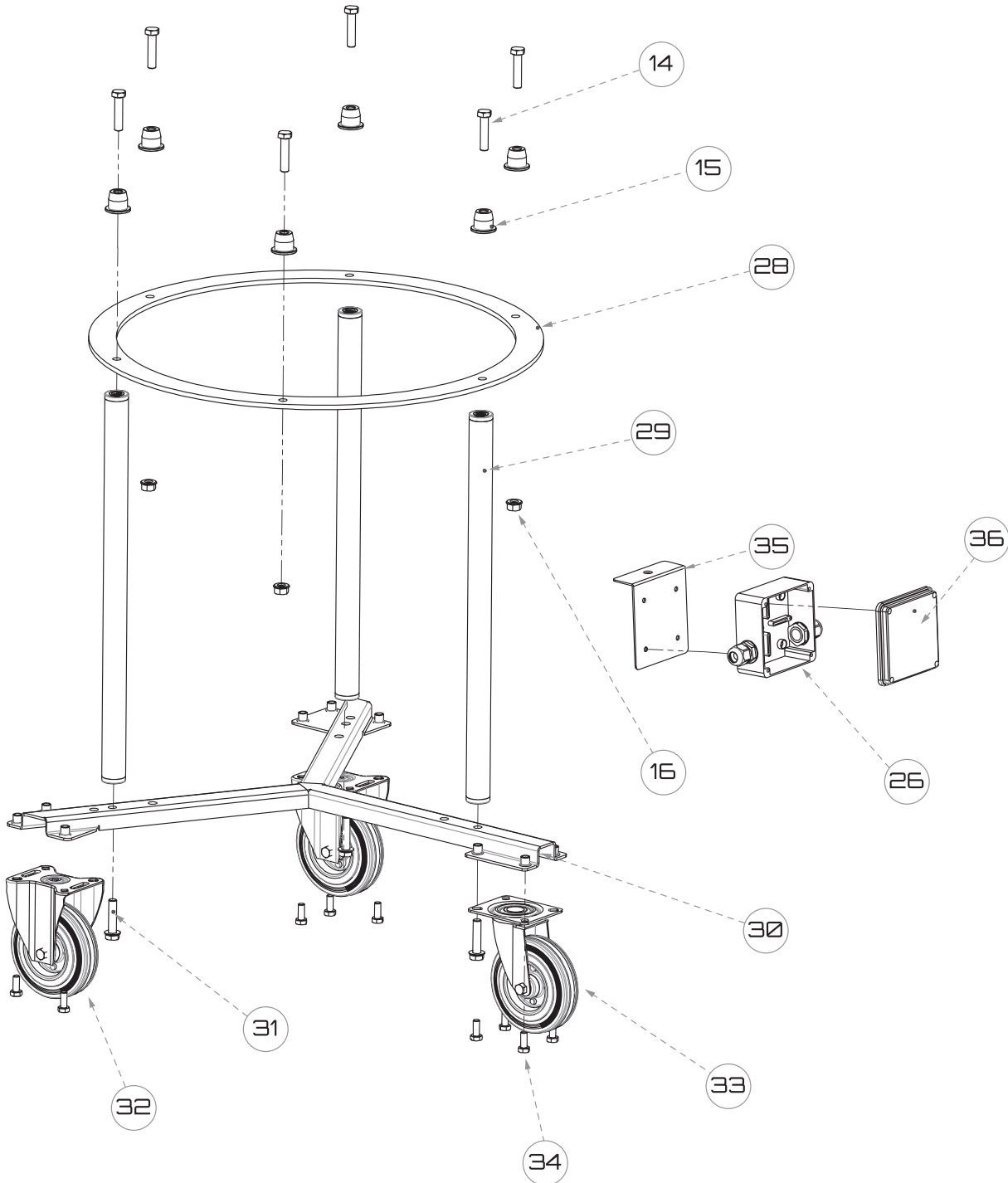

Parts Breakdown

Model GR-IT-1500-CR1200 47931

Vibrating Unit

Item No.	Description	Position	Item No.	Description	Position	Item No.	Description	Position
AJ872	Retaining Band for 47931	1	AJ877	Tightening Clamp for 47931	7 - 9	AJ882	Vibrator Motor for 47931	17
AJ873	Double Groove Screen Holder Frame for 47931	2	AJ878	Base Disk for 47931	10	AJ883	Trolley for 47931	20
AJ874	Screen Tensioning Rings for 47931	3	AJ879	Hex Head Bolts M10x40 for 47931	12	AJ884	Bedplate Hatch for 47931	21
AJ875	Full Thread Hex Head Screw M8x50 for 47931	4	AJ880	Spring for 47931	13	AJ885	"A" Shape Gasket for 47931	24
AJ876	Locking Ring for 47931	6	AJ881	Complete Lower Spring Guide for 47931	14 - 16	AJ886	Adhesive Flat Gasket for 47931	25

Model GR-IT-0300-CR800 47930

Vibrating Unit

Item No.	Description	Position	Item No.	Description	Position	Item No.	Description	Position
AJ887	Retaining Band for 47930	1	AJ892	Tightening Clamp for 47930	7 - 9	AJ897	Vibrator Motor for 47930	17
AJ888	Double Groove Screen Holder Frame for 47930	2	AJ893	Base Disk for 47930	10	AJ898	Trolley for 47930	20
AJ889	Screen Tensioning Rings for 47930	3	AJ894	Hex Head Bolts M10x40 for 47930	12	AJ899	Bedplate Hatch for 47930	21
AJ890	Full Thread Hex Head Screw M8x50 for 47930	4	AJ895	Spring for 47930	13	AJ900	"A" Shape Gasket for 47930	24
AJ891	Locking Ring for 47930	6	AJ896	Complete Lower Spring Guide for 47930	14 - 16	AJ901	Adhesive Flat Gasket for 47930	25

Model GR-IT-1500-CR1200 47931

Vibrating Unit Trolley

Model GR-IT-0300-CR800 47930

Item No.	Description	Position	Item No.	Description	Position	Item No.	Description	Position
AJ902	Hex Head Bolts M10x40 for 47931, 47930	14, 31	AJ906	Base Ring for 47931, 47930	28	AJ910	Castor Wheel Ø125/180 for 47931, 47930	33
AJ903	Spring Guide for 47931, 47930	15	AJ907	Column for 47931, 47930	29	AJ911	Hex Head Bolts M8x25 for 47931, 47930	34
AJ904	Nut M10 for 47931, 47930	16	AJ908	"Y" Shape Cross-Piece for 47931, 47930	30	AJ912	Plate for Junction Box for 47931, 47930	35
AJ905	Junction Box Contacts with Cable Glands for 47931, 47930	26	AJ909	Fixed Wheel Ø125/180 for 47931, 47930	32	AJ913	Lid for Junction Box for 47931, 47930	36



Warranty Registration

Thank you for purchasing an Omcan product. To register your warranty for this product, complete the information below, tear off the card at the perforation and then send to the address specified below. You can also register online by visiting:

Merci d'avoir acheté un produit Omcan. Pour enregistrer votre garantie pour ce produit, complétez les informations ci-dessous, détachez la carte au niveau de la perforation, puis l'envoyer à l'adresse spécifiée ci-dessous. Vous pouvez également vous inscrire en ligne en visitant:

Gracias por comprar un producto Omcan usted. Para registrar su garantía para este producto, complete la información a continuación, cortar la tarjeta en la perforación y luego enviarlo a la dirección indicada a continuación. También puede registrarse en línea en:

<https://omcan.com/warranty-registration/>

For mailing in Canada

Pour postale au Canada

Por correo en Canadá

OMCAN

PRODUCT WARRANTY REGISTRATION

3115 Pepper Mill Court,
Mississauga, Ontario
Canada, L5L 4X5

For mailing in the US

Pour diffusion aux États-Unis

Por correo en los EE.UU.

OMCAN

PRODUCT WARRANTY REGISTRATION

4450 Witmer Industrial Estates, Unit 4,
Niagara Falls, New York
USA, 14305

or email to: service@omcan.com



Purchaser's Information

Name: _____

Address: _____

City: _____ Province or State: _____ Postal or Zip: _____

Country: _____

Dealer from which Purchased: _____

Dealer City: _____ Dealer Province or State: _____

Invoice: _____

Model Name: _____ Model Number: _____

Machine Description: _____

Date of Purchase (MM/DD/YYYY): _____

Would you like to extend the warranty? Yes No

Company Name: _____

Telephone: _____

Email Address: _____

Type of Company:

Restaurant Bakery Deli

Butcher Supermarket Caterer

Institution (specify): _____

Other (specify): _____

Serial Number: _____

Date of Installation (MM/DD/YYYY): _____

Thank you for choosing Omcan | Merci d'avoir choisi Omcan | Gracias por elegir Omcan



Since 1951 Omcan has grown to become a leading distributor of equipment and supplies to the North American food service industry. Our success over these many years can be attributed to our commitment to strengthen and develop new and existing relationships with our valued customers and manufacturers. Today with partners in North America, Europe, Asia and South America, we continually work to improve and grow the company. We strive to offer customers exceptional value through our qualified local sales and service representatives who provide convenient access to over 6,500 globally sourced products.

Depuis 1951 Omcan a grandi pour devenir un des “leaders” de la distribution des équipements et matériel pour l’industrie des services alimentaires en Amérique du Nord. Notre succès au cours de ces nombreuses années peut être attribué à notre engagement à renforcer et à développer de nouvelles et existantes relations avec nos clients et les fabricants de valeur. Aujourd’hui avec des partenaires en Amérique du Nord, Europe, Asie et Amérique du Sud, nous travaillons continuellement à améliorer et développer l’entreprise. Nous nous efforçons d’offrir à nos clients une valeur exceptionnelle grâce à nos ventes locales qualifiées et des représentants de service qui offrent un accès facile à plus de 6500 produits provenant du monde entier.

Desde 1951 Omcan ha crecido hasta convertirse en un líder en la distribución de equipos y suministros de alimentos en América del Norte industria de servicios. Nuestro éxito en estos años se puede atribuir a nuestro compromiso de fortalecer y desarrollar nuevas relaciones existentes con nuestros valiosos clientes y fabricantes. Hoy con socios de América del Norte, Europa, Asia y América del Sur, que trabajan continuamente para mejorar y crecer la empresa. Nos esforzamos por ofrecer a nuestros clientes valor excepcional a través de nuestro local de ventas y representantes de los servicios que proporcionan un fácil acceso a más de 6,500 productos con origen a nivel mundial.

