



Dough Mixers
Models MX-CN-0037, 0043, 0053
Items 19194, 19195, 19196
Instruction Manual



Revised - 11/22/2018



Toll Free: 1-800-465-0234
Fax: 905-607-0234
Email: service@omcan.com
www.omcan.com



Table of Contents

Model MX-CN-0037 / Model MX-CN-0043 / Model MX-CN-0053

Section	Page
General Information -----	3 - 4
Safety and Warranty -----	4 - 5
Technical Specifications -----	6
Operation -----	6
Maintenance -----	7
Troubleshooting -----	7
Parts Breakdown -----	8 - 9
Electrical Schematics -----	10
Warranty Registration -----	11



General Information

Omcan Manufacturing and Distributing Company Inc., Food Machinery of America, Inc. dba Omcan and Omcan Inc. are not responsible for any harm or injury caused due to any person's improper or negligent use of this equipment. The product shall only be operated by someone over the age of 18, of sound mind, and not under the influence of any drugs or alcohol, who has been trained in the correct operation of this machine, and is wearing authorized, proper safety clothing. Any modification to the machine voids any warranty, and may cause harm to individuals using the machine or in the vicinity of the machine while in operation.

CHECK PACKAGE UPON ARRIVAL

Upon receipt of an Omcan shipment please inspect for external damage. If no damage is evident on the external packaging, open carton to ensure all ordered items are within the box, and there is no concealed damage to the machine. If the package has suffered rough handling, bumps or damage (visible or concealed), please note it on the bill of lading before accepting the delivery and contact Omcan within 24 hours, so we may initiate a claim with the carrier. A detailed report on the extent of the damage caused to the machine must be filled out within three days, from the delivery date shown in the shipping documents. Omcan has no recourse for damaged products that were shipped collect or third party.

Before operating any equipment, always read and familiarize yourself with all operation and safety instructions.

Omcan would like to thank you for purchasing this machine. It's of the utmost importance to save these instructions for future reference. Also save the original box and packaging for shipping the equipment if servicing or returning of the machine is required.

Omcan Fabrication et distribution Compañie Limité et Food Machinery d'Amérique, dba Omcan et Omcan Inc. ne sont pas responsables de tout dommage ou blessure causé du fait que toute personne ait utilisé cet équipement de façon irrégulière. Le produit ne doit être exploité que par quelqu'un de plus de 18 ans, saine d'esprit, et pas sous l'influence d'une drogue ou d'alcool, qui a été formé pour utiliser cette machine correctement, et est vêtu de vêtements de sécurité approprié. Toute modification de la machine annule toute garantie, et peut causer un préjudice à des personnes utilisant la machine ou des personnes à proximité de la machine pendant son fonctionnement.

VÉRIFIEZ LE COLIS DÈS RÉCEPTION

Dès réception d'une expédition d'Omcan veuillez inspecter pour dommages externes. Si aucun dommage n'est visible sur l'emballage externe, ouvrez le carton afin de s'assurer que tous les éléments commandés sont dans la boîte, et il n'y a aucun dommage dissimulé à la machine. Si le colis n'a subi aucune mauvaises manipulations, de bosses ou de dommages (visible ou cachée), notez-le sur le bond de livraison avant d'accepter la livraison et contactez Omcan dans les 24 heures qui suivent, pour que nous puissions engager une réclamation auprès du transporteur. Un rapport détaillé sur l'étendue des dommages causés à la machine doit être rempli dans un délai de trois jours, à compter de la date de livraison indiquée dans les documents d'expédition. Omcan n'a aucun droit de recours pour les produits endommagés qui ont été expédiés ou cueilli par un tiers transporteur.

General Information

Avant d'utiliser n'importe quel équipement, toujours lire et vous familiariser avec toutes les opérations et les consignes de sécurité.

Omcan voudrais vous remercier d'avoir choisi cette machine. Il est primordial de conserver ces instructions pour une référence ultérieure. Également conservez la boîte originale et l'emballage pour l'expédition de l'équipement si l'entretien ou le retour de la machine est nécessaire.

Omcan Empresa De Fabricacion Y Distribucion Inc. Y Maquinaria De Alimentos De America, Inc. dba Omcan y Omcan Inc. no son responsables de ningun daño o perjuicio causado por cualquier persona inadecuada o el uso descuidado de este equipo. El producto solo podra ser operado por una persona mayor de 18 años, en su sano juicio y no bajo alguna influencia de droga o alcohol, y que este ha sido entrenado en el correcto funcionamiento de esta máquina, y ésta usando ropa apropiada y autorizada. Cualquier modificación a la máquina anula la garantía y puede causar daños a las personas usando la máquina mientras esta en el funcionamiento.

REVISE EL PAQUETE A SU LLEGADA

Tras la recepcion de un envio Omcan favor inspeccionar daños externos. Si no hay daños evidentes en el empaque exterior, Habra el carton para asegurarse que todos los articulos solicitados estén dentro de la caja y no encuentre daños ocultos en la máquina. Si el paquete ha sufrido un manejo de poco cuidado, golpes o daños (visible o oculto) por favor anote en la factura antes de aceptar la entrega y contacte Omcan dentro de las 24 horas, de modo que podamos iniciar una reclamación con la compañía. Un informe detallado sobre los daños causados a la máquina debe ser llenado en el plazo de tres días, desde la fecha de entrega que se muestra en los documentos de envío. Omcan no tiene ningun recurso por productos dañados que se enviaron a recoger por terceros.

Antes de utilizar cualquier equipo, siempre lea y familiarizarse con todas las instrucciones de funcionamiento y seguridad.

Omcan le gustaría darle las gracias por la compra de esta máquina. Es de la mayor importancia para salvar estas instrucciones para futuras consultas. Además, guarda la caja original y el embalaje para el envío del equipo si servicio técnico o devolución de la máquina que se requiere.

Safety and Warranty

ATTENTION

- Repairing this product must be performed by qualified persons and those who are authorized by the manufacturer.
- When installing or maintaining, please obey the following instructions carefully to ensure the safe use of this appliance.
- Please keep this instruction manual for future reference.

Safety and Warranty

- Remove the packaging to make sure none of the parts are missing or damaged. If there is any doubt about the product, please do not use it, and contact the manufacturer.
- Keep the packing material out of reach of children to avoid accidents (especially the plastic bag, screw etc).
- This appliance can only be operated by a person who is competent with the unit.
- When not using the appliance or the operator is absent, please turn off the unit to avoid any accidental injury or damage.
- When it needs to be repaired, contact an authorized service agent, and only use the original fitted spare parts, otherwise a hazard may occur.
- This appliance is for commercial use only. Do not use for any other purpose, otherwise it may cause a hazard.
- Do not rinse the equipment with water spray.
- Clean the surface of the stainless steel periodically and appropriately to prevent any damage brought by oxidization or any other chemical interference.

1 YEAR PART AND LABOUR BENCH WARRANTY

Within the warranty period, contact Omcan Inc. at 1-800-465-0234 to schedule a drop off to either an Omcan authorized service depot in the area, or to an Omcan Service warehouse to repair the equipment.

Unauthorized maintenance will void the warranty. Warranty covers electrical and part failures, not improper use.

Please see <https://omcan.com/disclaimer> for complete info.

WARNING:

The packaging components are classified as normal solid urban waste and can therefore be disposed of without difficulty.

In any case, for suitable recycling, we suggest disposing of the products separately (differentiated waste) according to the current norms.

DO NOT DISCARD ANY PACKAGING MATERIALS IN THE ENVIRONMENT!

Technical Specifications

Model	MX-CN-0037	MX-CN-0043	MX-CN-0053
Rated Voltage	220V / 60Hz / 3		
IPON	IPX1		
Power (kw)	0.85 / 1.1	1.1 / 2.2	
Rated Input Power (kw)	1.55	2.7	
Bowl Volume	35 L / 37 QT	40 L / 42 QT	50 L / 53 QT
Flour Max Quantity	12 kg. / 26 lbs.	16 kg. / 35 lbs.	20 kg. / 44 lbs.
Dimensions	30" x 17" x 32"	34" x 19" x 37"	36" x 21" x 37"
	770 x 430 x 810 mm	870 x 480 x 935 mm	920 x 530 x 935 mm
Weight	95 kg. / 209 lbs.	127 kg. / 280 lbs.	130 kg. / 287 lbs.
Item Number	19194	19195	19196

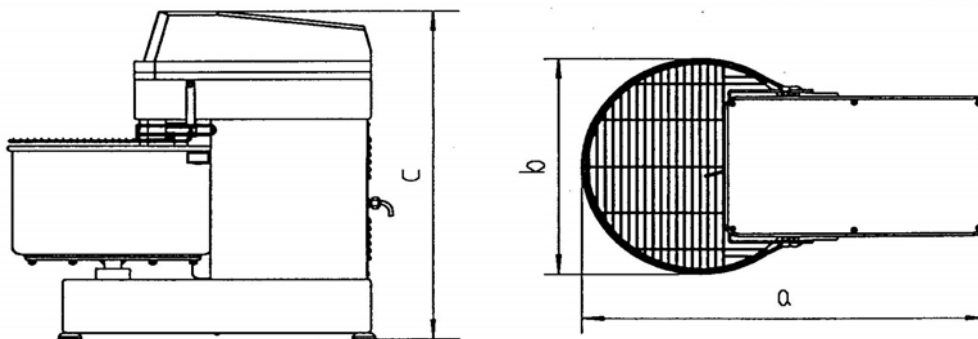

Operation

1. Place mixer on a dry stable location, and make certain that it is secure.
2. Before use, ensure that the power supply corresponds to that required by the machine and that the external ground wire is securely connected.
3. Ensure that flour mixing capacity is lower than the max. flour capacity.
4. Before starting, make sure that the safety protective guard has been lowered.
5. Do not put hands or hard objects into the bowl while in operation.

Not to be operated without protective casing.

Maintenance

1. Continuous run times are not advised, allow the machine to rest periodically.
2. After each use, clean the machine, to avoid bacteria growth.
3. The transmission case is packed with special grease that will last for six months. To add or replace the grease, it is necessary to remove the upper cover. This should be done by an Omcan authorized provider.

Note: Before maintaining the unit, the machine must be unplugged from the power supply.

Troubleshooting

Trouble	Probable cause	Remedy
The mixing shaft does not rotate after being turned on.	Electric connectors are loose.	Check the electric circuit, tighten any loose connectors.
The square rod trembles.	The lock bolts are loose.	Tighten the bolts.
The temperature of the motor rises beyond normal, or it runs at a slower speed.	Lack of voltage.	Check the supply voltage.
	Over loaded.	Remove some of the product.
The noise of the transmission case is loud.	Insufficient amount of lubrication.	Add or replace the grease.
	The chains are loose.	Tighten the chains.
The agitator hits the bowl in operation.	The agitator or the bowl is deformed.	Repair or replace deformed part.

REFERENCE

Item Number	Model Number	Description	Manufacturer Model Number
19194	MX-CN-0037	Mixer Spiral Dough 37 QT / 9 GAL 1.1-1.5 HP / 820-1119 W 220V/60/3	HS30DA
19195	MX-CN-0043	Mixer Spiral Dough 43 QT / 11 GAL 1.5-3 HP / 1119-2237 W 220V/60/3	HS40DA
19196	MX-CN-0053	Mixer Spiral Dough 53 QT / 13 GAL 1.5-3 HP / 1119-2237 W 220V/60/3	HS50DA

Parts Breakdown

Model MX-CN-0037 19194

Model MX-CN-0043 19195

Model MX-CN-0053 19196

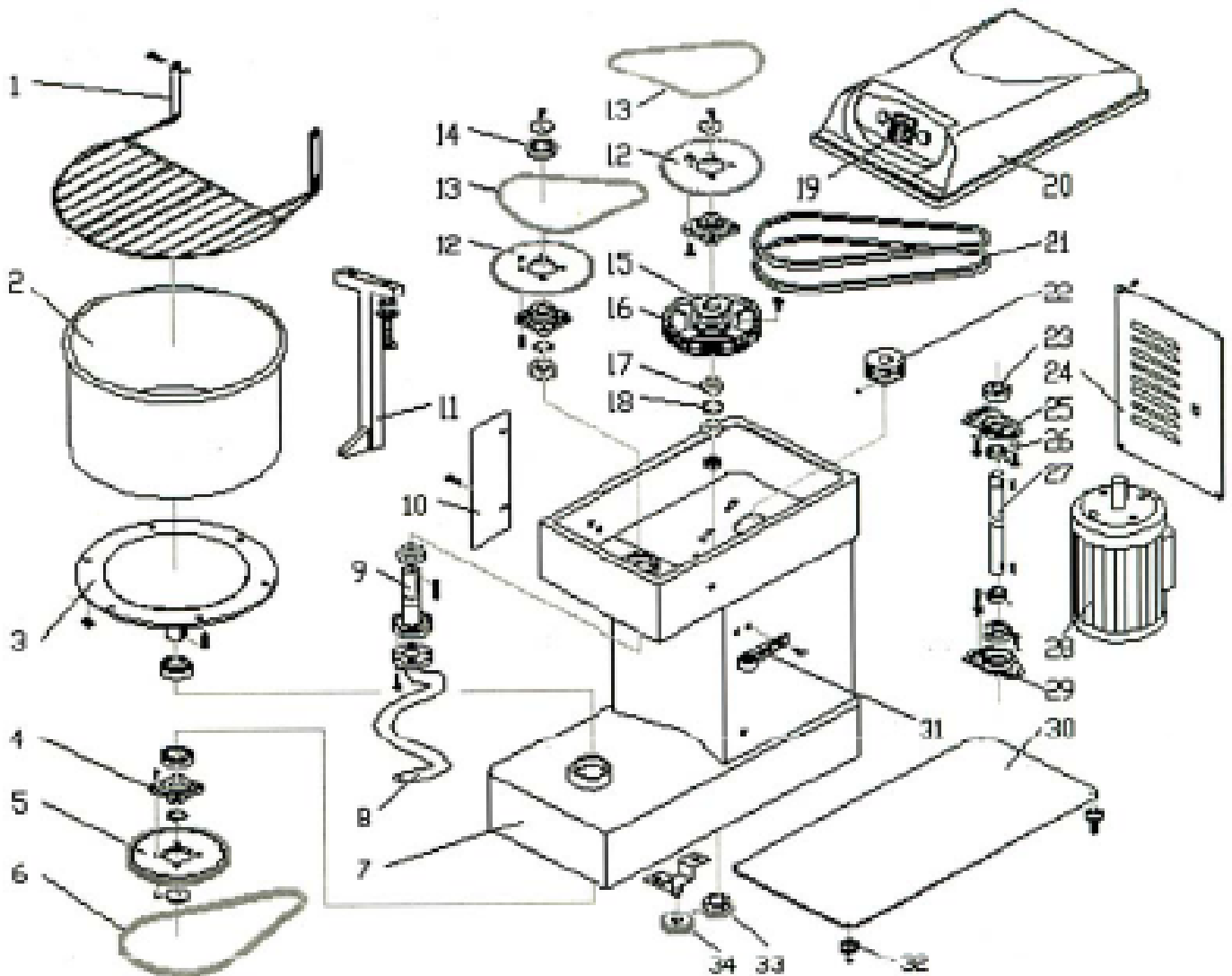



Parts Breakdown

Model MX-CN-0037 19194

Item No.	Description	Position	Item No.	Description	Position	Item No.	Description	Position
75463	Protective Casing for HS30DA	1	75474	Chain for HS30DA	12	75485	Back Cover for HS30DA	23
75464	Bowl for HS30DA	2	75475	Chain Pulley Z = 19 for HS30DA	13	75486	Bearing Seat for HS30DA	24
75465	Bowl Support for HS30DA	3	75476	Chain Pulley Z = 19 for HS30DA	14	75487	Locking Ring for HS30DA	25
75466	Chain Seat for HS30DA	4	75477	Big Belt Pulley for HS30DA	15	75488	Transmission Shaft for HS30DA	26
75467	Big Chain Pulley Z = 75 for HS30DA	5	75478	Washer for HS30DA	16	75489	Motor for HS30DA	27
75468	Chain for HS30DA	6	75479	Washer for HS30DA	17	75490	Bearing Seat for HS30DA	28
75469	Frame for HS30DA	7	75480	Washer for HS30DA	18	75491	Bottom Plate for HS30DA	29
75470	Dough Arm for HS30DA	8	75481	Top Cover for HS30DA	19	75492	Guiding Wheel for HS30DA	30
75471	Shaft for HS30DA	9	75482	Belt for HS30DA	20	75493	Rubber Foot for HS30DA	31
75472	Protective Plate for HS30DA	10	75483	Small Belt Pulley for HS30DA	21	75494	Bottom Pulley Z = 19 for HS30DA	32
75473	Center Rod for HS30DA	11	75484	Motor Fixed Plate for HS30DA	22	75495	Tension Pulley Z = 19 for HS30DA	33

Model MX-CN-0043 19195

Item No.	Description	Position	Item No.	Description	Position	Item No.	Description	Position
76963	Protective Casing for HS40DA	1	76974	Chain for HS40DA	12	76985	Back Cover for HS40DA	23
76964	Bowl for HS40DA	2	76975	Chain Pulley Z = 19 for HS40DA	13	76986	Bearing Seat for HS40DA	24
76965	Bowl Support for HS40DA	3	76976	Chain Pulley Z = 19 for HS40DA	14	76987	Locking Ring for HS40DA	25
76966	Chain Seat for HS40DA	4	76977	Big Belt Pulley for HS40DA	15	76988	Transmission Shaft for HS40DA	26
76967	Big Chain Pulley Z = 75 for HS40DA	5	76978	Washer for HS40DA	16	76989	Motor for HS40DA	27
76968	Chain for HS40DA	6	76979	Washer for HS40DA	17	76990	Bearing Seat for HS40DA	28
76969	Frame for HS40DA	7	76980	Washer for HS40DA	18	76991	Bottom Plate for HS40DA	29
76970	Dough Arm for HS40DA	8	76981	Top Cover for HS40DA	19	76992	Guiding Wheel for HS40DA	30
76971	Shaft for HS40DA	9	76982	Belt for HS40DA	20	76993	Rubber Foot for HS40DA	31
76972	Protective Plate for HS40DA	10	76983	Small Belt Pulley for HS40DA	21	76994	Bottom Pulley Z = 19 for HS40DA	32
76973	Center Rod for HS40DA	11	76984	Motor Fixed Plate for HS40DA	22	76995	Tension Pulley Z = 19 for HS40DA	33

Model MX-CN-0053 19196

Item No.	Description	Position	Item No.	Description	Position	Item No.	Description	Position
76996	Protective Casing for HS50DA	1	77007	Chain for HS50DA	12	77018	Back Cover for HS50DA	23
76997	Bowl for HS50DA	2	77008	Chain Pulley Z = 19 for HS50DA	13	77019	Bearing Seat for HS50DA	24
76998	Bowl Support for HS50DA	3	77009	Chain Pulley Z = 19 for HS50DA	14	77020	Locking Ring for HS50DA	25
76999	Chain Seat for HS50DA	4	77010	Big Belt Pulley for HS50DA	15	77021	Transmission Shaft for HS50DA	26
77000	Big Chain Pulley Z = 75 for HS50DA	5	77011	Washer for HS50DA	16	77022	Motor for HS50DA	27
77001	Chain for HS50DA	6	77012	Washer for HS50DA	17	77023	Bearing Seat for HS50DA	28
77002	Frame for HS50DA	7	77013	Washer for HS50DA	18	77024	Bottom Plate for HS50DA	29
77003	Dough Arm for HS50DA	8	77014	Top Cover for HS50DA	19	77025	Guiding Wheel for HS50DA	30
77004	Shaft for HS50DA	9	77015	Belt for HS50DA	20	77026	Rubber Foot for HS50DA	31
77005	Protective Plate for HS50DA	10	77016	Small Belt Pulley for HS50DA	21	77027	Bottom Pulley Z = 19 for HS50DA	32
77006	Center Rod for HS50DA	11	77017	Motor Fixed Plate for HS50DA	22	77028	Tension Pulley Z = 19 for HS50DA	33

Electrical Schematics

Model MX-CN-0037 19194

Model MX-CN-0043 19195

Model MX-CN-0053 19196

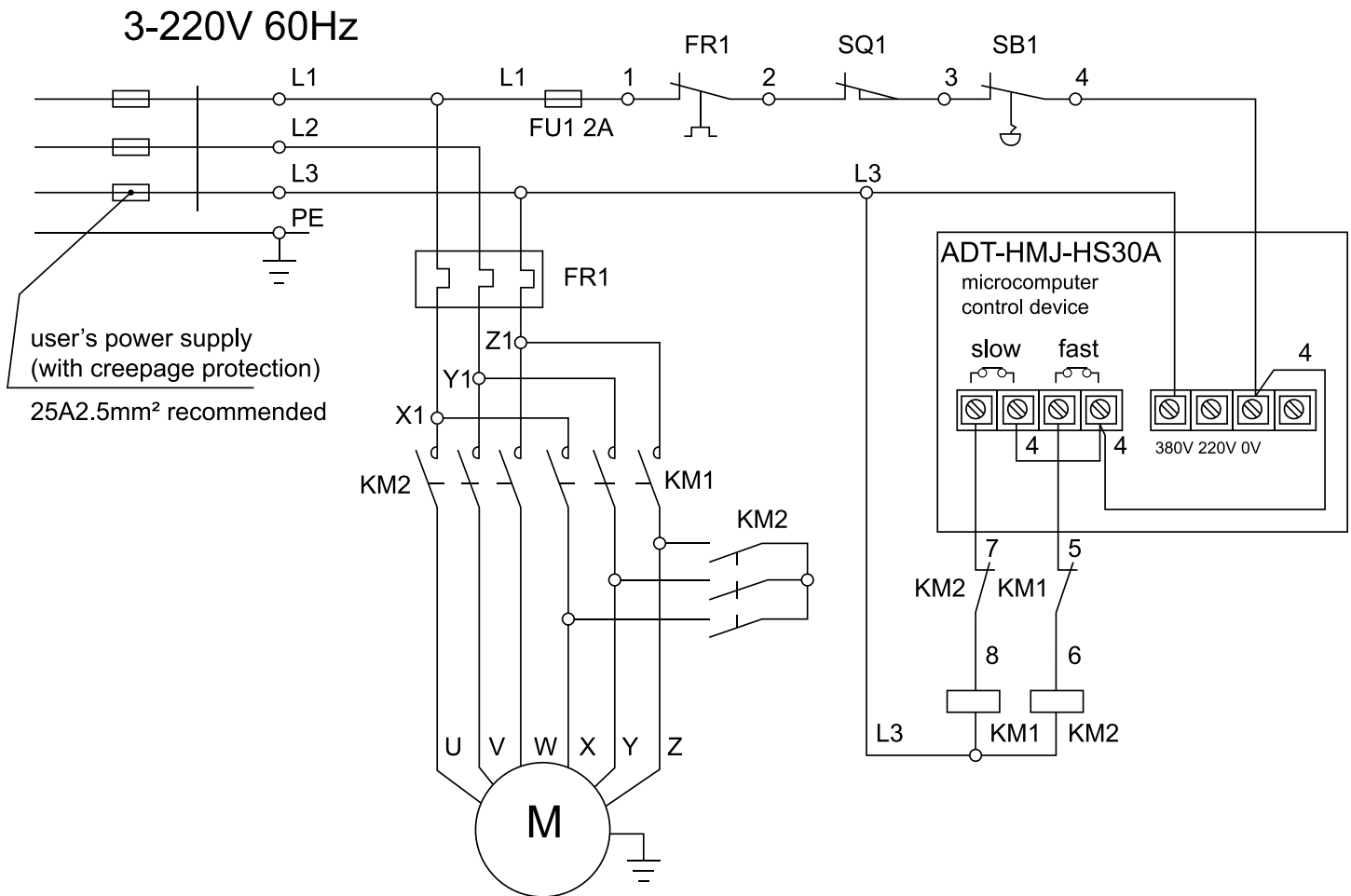

Bi-Speed Motor

Item	Description	Item	Description
A1	Micro-Computer Controller	SQ1	Journey Switch
M	Motor	SB1	Push-Lock/Turn-Reset Switch
KM1/2	Contactor	FU1	Fusioner Fuse 2A
FR1	Heat Relay		



Warranty Registration

Thank you for purchasing an Omcan product. To register your warranty for this product, complete the information below, tear off the card at the perforation and then send to the address specified below. You can also register online by visiting:

Merci d'avoir acheté un produit Omcan. Pour enregistrer votre garantie pour ce produit, complétez les informations ci-dessous, détachez la carte au niveau de la perforation, puis l'envoyer à l'adresse spécifiée ci-dessous. Vous pouvez également vous inscrire en ligne en visitant:

Gracias por comprar un producto Omcan usted. Para registrar su garantía para este producto, complete la información a continuación, cortar la tarjeta en la perforación y luego enviarlo a la dirección indicada a continuación. También puede registrarse en línea en:

<https://omcan.com/warranty-registration/>

For mailing in Canada

Pour postale au Canada

Por correo en Canadá

OMCAN

PRODUCT WARRANTY REGISTRATION

3115 Pepper Mill Court,

Mississauga, Ontario

Canada, L5L 4X5

For mailing in the US

Pour diffusion aux États-Unis

Por correo en los EE.UU.

OMCAN

PRODUCT WARRANTY REGISTRATION

4450 Witmer Industrial Estates, Unit 4,

Niagara Falls, New York

USA, 14305

or email to: service@omcan.com



Purchaser's Information

Name: _____

Address: _____

City: _____ Province or State: _____ Postal or Zip: _____

Country: _____

Dealer from which Purchased: _____

Dealer City: _____ Dealer Province or State: _____

Invoice: _____

Model Name: _____ Model Number: _____

Machine Description: _____

Date of Purchase (MM/DD/YYYY): _____

Would you like to extend the warranty? Yes No

Company Name: _____

Telephone: _____

Email Address: _____

Type of Company:

Restaurant Bakery Deli

Butcher Supermarket Caterer

Institution (*specify*): _____

Other (*specify*): _____

Serial Number: _____

Date of Installation (MM/DD/YYYY): _____

Thank you for choosing Omcan | Merci d'avoir choisi Omcan | Gracias por elegir Omcan



Since 1951 Omcan has grown to become a leading distributor of equipment and supplies to the North American food service industry. Our success over these many years can be attributed to our commitment to strengthen and develop new and existing relationships with our valued customers and manufacturers. Today with partners in North America, Europe, Asia and South America, we continually work to improve and grow the company. We strive to offer customers exceptional value through our qualified local sales and service representatives who provide convenient access to over 5,000 globally sourced products.

Depuis 1951 Omcan a grandi pour devenir un des “leaders” de la distribution des équipements et matériel pour l’industrie des services alimentaires en Amérique du Nord. Notre succès au cours de ces nombreuses années peut être attribué à notre engagement à renforcer et à développer de nouvelles et existantes relations avec nos clients et les fabricants de valeur. Aujourd’hui avec des partenaires en Amérique du Nord, Europe, Asie et Amérique du Sud, nous travaillons continuellement à améliorer et développer l’entreprise. Nous nous efforçons d’offrir à nos clients une valeur exceptionnelle grâce à nos ventes locales qualifiées et des représentants de service qui offrent un accès facile à plus de 5000 produits provenant du monde entier.

Desde 1951 Omcan ha crecido hasta convertirse en un líder en la distribución de equipos y suministros de alimentos en América del Norte industria de servicios. Nuestro éxito en estos años se puede atribuir a nuestro compromiso de fortalecer y desarrollar nuevas relaciones existentes con nuestros valiosos clientes y fabricantes. Hoy con socios de América del Norte, Europa, Asia y América del Sur, que trabajan continuamente para mejorar y crecer la empresa. Nos esforzamos por ofrecer a nuestros clientes valor excepcional a través de nuestro local de ventas y representantes de los servicios que proporcionan un fácil acceso a más de 5,000 productos con origen a nivel mundial.

