

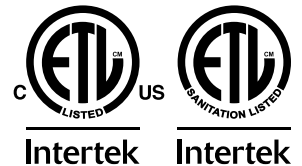

***Open Refrigerated Display Case***  
***Model RS-CN-0250***  
***Item 25825***  
***Instruction Manual***



*Revised - 08/25/2022*



Toll Free: 1-800-465-0234  
Fax: 905-607-0234  
Email: [service@omcan.com](mailto:service@omcan.com)  
[www.omcan.com](http://www.omcan.com)

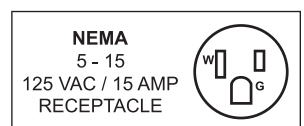

# ***Table of Contents***

Model RS-CN-0250

---

<b>Section</b>	<b>Page</b>
Disclaimer -----	3
General Information -----	4 - 5
Safety and Warranty -----	5 - 6
Technical Specifications -----	7
Handling and Assembly -----	7 - 8
Operation -----	8 - 9
Maintenance -----	9
Troubleshooting -----	9 - 10
Controller Instructions -----	11 - 14
Parts Breakdown -----	15 - 17
Electrical Schematics -----	18
Warranty Registration -----	19

***OMCAN IS NOT RESPONSIBLE FOR DIMINISHED COOLING OR ANY DAMAGES DUE TO WATER LEAKS. WARRANTY FOR WATER LEAKS IS VOID IF THE AMBIENT ROOM TEMPERATURE EXCEEDS 75°F AND 55% RELATIVE HUMIDITY, AND THE APPLIANCE DRAIN IS NOT CONNECTED DIRECTLY TO A FLOOR DRAIN.***

# ***General Information***

---

**Omcan Manufacturing and Distributing Company Inc., Food Machinery of America, Inc. dba Omcan and Omcan Inc. are not responsible for any harm or injury caused due to any person's improper or negligent use of this equipment. The product shall only be operated by someone over the age of 18, of sound mind, and not under the influence of any drugs or alcohol, who has been trained in the correct operation of this machine, and is wearing authorized, proper safety clothing. Any modification to the machine voids any warranty, and may cause harm to individuals using the machine or in the vicinity of the machine while in operation.**

## **CHECK PACKAGE UPON ARRIVAL**

Upon receipt of an Omcan shipment please inspect for external damage. If no damage is evident on the external packaging, open carton to ensure all ordered items are within the box, and there is no concealed damage to the machine. If the package has suffered rough handling, bumps or damage (visible or concealed), please note it on the bill of lading before accepting the delivery and contact Omcan within 24 hours, so we may initiate a claim with the carrier. A detailed report on the extent of the damage caused to the machine must be filled out within three days, from the delivery date shown in the shipping documents. Omcan has no recourse for damaged products that were shipped collect or third party.

**Before operating any equipment, always read and familiarize yourself with all operation and safety instructions.**

**Omcan would like to thank you for purchasing this machine. It's of the utmost importance to save these instructions for future reference. Also save the original box and packaging for shipping the equipment if servicing or returning of the machine is required.**

---

**Omcan Fabrication et distribution Compagnie Limitée et Food Machinery d'Amérique, dba Omcan et Omcan Inc. ne sont pas responsables de tout dommage ou blessure causé du fait que toute personne ait utilisé cet équipement de façon irrégulière. Le produit ne doit être exploité que par quelqu'un de plus de 18 ans, sain d'esprit, et pas sous l'influence d'une drogue ou d'alcool, qui a été formé pour utiliser cette machine correctement, et est vêtu de vêtements de sécurité appropriés. Toute modification de la machine annule toute garantie, et peut causer un préjudice à des personnes utilisant la machine ou des personnes à proximité de la machine pendant son fonctionnement.**

## **VÉRIFIEZ LE COLIS DÈS RÉCEPTION**

Dès réception d'une expédition d'Omcan veuillez inspecter pour dommages externes. Si aucun dommage n'est visible sur l'emballage externe, ouvrez le carton afin de s'assurer que tous les éléments commandés sont dans la boîte, et il n'y a aucun dommage dissimulé à la machine. Si le colis n'a subi aucune mauvaises manipulations, de bosses ou de dommages (visible ou cachée), notez-le sur le bond de livraison avant d'accepter la livraison et contactez Omcan dans les 24 heures qui suivent, pour que nous puissions engager une réclamation auprès du transporteur. Un rapport détaillé sur l'étendue des dommages causés à la machine doit être rempli dans un délai de trois jours, à compter de la date de livraison indiquée dans les documents d'expédition. Omcan n'a aucun droit de recours pour les produits endommagés qui ont été expédiés ou cueilli par un tiers transporteur.



# General Information

---

Avant d'utiliser n'importe quel équipement, toujours lire et vous familiariser avec toutes les opérations et les consignes de sécurité.

Omcan voudrais vous remercier d'avoir choisi cette machine. Il est primordial de conserver ces instructions pour une référence ultérieure. Également conservez la boîte originale et l'emballage pour l'expédition de l'équipement si l'entretien ou le retour de la machine est nécessaire.

---

Omcan Empresa De Fabricacion Y Distribucion Inc. Y Maquinaria De Alimentos De America, Inc. dba Omcan y Omcan Inc. no son responsables de ningun daño o perjuicio causado por cualquier persona inadecuada o el uso descuidado de este equipo. El producto solo podra ser operado por una persona mayor de 18 años, en su sano juicio y no bajo alguna influencia de droga o alcohol, y que este ha sido entrenado en el correcto funcionamiento de esta máquina, y ésta usando ropa apropiada y autorizada. Cualquier modificación a la máquina anula la garantía y puede causar daños a las personas usando la máquina mientras esta en el funcionamiento.

## REVISE EL PAQUETE A SU LLEGADA

Tras la recepcion de un envio Omcan favor inspeccionar daños externos. Si no hay daños evidentes en el empaque exterior, Habra el carton para asegurarse que todos los articulos solicitados estén dentro de la caja y no encuentre daños ocultos en la máquina. Si el paquete ha sufrido un manejo de poco cuidado, golpes o daños (visible o oculto) por favor anote en la factura antes de aceptar la entrega y contacte Omcan dentro de las 24 horas, de modo que podamos iniciar una reclamación con la compañía. Un informe detallado sobre los daños causados a la máquina debe ser llenado en el plazo de tres días, desde la fecha de entrega que se muestra en los documentos de envío. Omcan no tiene ningun recurso por productos dañados que se enviaron a recoger por terceros.

**Antes de utilizar cualquier equipo, siempre lea y familiarizarse con todas las instrucciones de funcionamiento y seguridad.**

Omcan le gustaría darle las gracias por la compra de esta máquina. Es de la mayor importancia para salvar estas instrucciones para futuras consultas. Además, guarda la caja original y el embalaje para el envío del equipo si servicio técnico o devolución de la máquina que se requiere.

# Safety and Warranty

---

## Cautions:

- Never block the air suction outlet to keep air circulation and refrigeration capability.
- Do not overfill the unit or it may hinder its operation.
- Adjust the rack height for proper food storage.

# ***Safety and Warranty***

---

## **Use and Caution:**

- Cool hot food before placing it in the refrigerator.
- Only trained technicians should repair damaged power cables with special tools.
- Never touch the compressor to avoid injury.
- This appliance is not intended for use by persons (including children) with reduced physical, sensory or mental capabilities or lack of experience and knowledge, unless they have been given supervision or instruction concerning use of the appliance by a person responsible for their safety.
- Children should be supervised to ensure that they do not play with or around the appliance.
- The operation manual is not suitable for persons (including children) with reduced physical, sensory or mental capabilities, or lack of experience and knowledge.

**SUITABLE FOR HIGH TRAFFIC AREAS WHERE NOISE LEVELS ARE NOT A CONCERN.**

**OMCAN IS NOT RESPONSIBLE FOR DIMINISHED COOLING OR ANY DAMAGES DUE TO WATER LEAKS. WARRANTY FOR WATER LEAKS IS VOID IF THE AMBIENT ROOM TEMPERATURE EXCEEDS 75°F AND 55% RELATIVE HUMIDITY, AND THE APPLIANCE DRAIN IS NOT CONNECTED DIRECTLY TO THE FLOOR DRAIN.**

**RESIDENTIAL USERS: Vendor assumes no liability for parts or labor coverage for component failure or other damages resulting from installation in non-commercial or residential applications. The right is reserved to deny shipment for residential usage; if this occurs, you will be notified as soon as possible.**

## **1 YEAR PARTS AND LABOUR WARRANTY**

**Within the warranty period, contact Omcan Inc. at 1-800-465-0234 to schedule an Omcan authorized service technician to repair the equipment locally.**

**Unauthorized maintenance will void the warranty. Warranty covers electrical and part failures, not improper use.**

**Please see <https://omcan.com/disclaimer> for complete info.**

## **WARNING:**

The packaging components (cardboard, polyethylene, and others) are classified as normal solid urban waste and can therefore be disposed of without difficulty.

**In any case, for suitable recycling, we suggest disposing of the products separately (differentiated waste) according to the current norms.**

**DO NOT DISCARD ANY PACKAGING MATERIALS IN THE ENVIRONMENT!**

# Technical Specifications

<b>Model</b>	<b>RS-CN-0250</b>
<b>Power</b>	0.138 kW
<b>Electrical Heating Element</b>	0.45 kW
<b>Capacity</b>	252 L / 8.9 cu.ft.
<b>Electrical</b>	110V / 60Hz / 1
<b>Lamp Power</b>	1.44 W x 4 (LED)
<b>Temperature Range</b>	2 - 10°C / 36 - 50 °F
<b>Max Ambient Temp Rating</b>	24°C / 75°F
<b>Refrigerant and Injection</b>	R290 (148g)
<b>Blowing Gas</b>	Cyclopentane
<b>Type of Climate</b>	6
<b>Rated Current</b>	14.5A
<b>Weight</b>	220.5 lbs. / 100 kgs.
<b>Packaging Weight</b>	242.5 lbs. / 110 kgs.
<b>Dimensions</b>	24" x 29.7" x 67.8" / 610 x 754 x 1704mm
<b>Inner Dimensions</b>	21.8" x 22" x 38.5" / 552 x 559 x 978mm
<b>Shelf Dimensions</b>	15" x 21.8" / 381 x 552mm (2pc.) 12" x 21.8" / 305 x 552mm (1pc.)
<b>Packaging Dimensions</b>	27.2" x 29.7" x 73.8" / 691 x 830 x 1875mm
<b>Item Number</b>	25825

# Handling and Assembly

<p><b>Handle with care</b> Unplug the wall socket first. Never tilt it over 45 degrees when handling.</p>	<p><b>Dry place</b> Always locate the refrigerator in a dry location.</p>
<p><b>Sufficient space</b> The distance from both sides and back of refrigerator to wall or other substance must be no less than 10 cm. The refrigeration capability may decrease if its surrounding space is too small to circulate air.</p>	<p><b>Well ventilated</b> Always locate the refrigerator in an area with good ventilation. When using for the first time, wait for 24 hours after handling to start.</p>
<p><b>Far from heat source</b> Never place the refrigerator direction under sunlight. Never locate it near any heat source to prevent reducing refrigeration capability.</p>	<p><b>No heavy load</b> Never put any heavy objects on top of the refrigerator.</p>

# Handling and Assembly

<b>Do not make holes</b> Never make any holes on the refrigerator. Do not attach any objects onto the refrigerator.	<b>Stable Location</b> Unpack and place the refrigerator on flat and stable ground.
<b>Exclusive power socket</b> Normally, the power supply should be 100 – 110V, 60 Hz single phase AC with exclusive single phase two pin receptacle.	<b>Do not share the socket</b> Never let the refrigerator share a socket with another appliance. The cable may become hot and this may cause a fire.
<b>Protect cables</b> Never break or damage the cables as this may cause electrical shock.	<b>No water flushing</b> Never give the refrigerator surface a flush otherwise electrical shock may occur.
<b>Avoid flammable and explosive objects</b> Never put any flammable or explosive items inside the refrigerator such as gasoline or alcohol. Never put any dangerous product nearby the refrigerator.	<b>No spray</b> Do not spray the unit with a flammable substance such as paint. This may result in a fire.
<b>After power break</b> After power break or unplugging the refrigerator, always wait at least 5 minutes before starting the refrigerator again.	<b>No medicine</b> No medicine is allowed to be kept inside the refrigerator.

# Operation

## Before use:

Plug the refrigerator into 110V exclusive socket. Unit must have independent breaker. After the refrigerator is running, test the air suction to confirm that it is sufficiently cold. Then you may put food and drinks inside, once unit reaches temperature.

## Parameter Settings

**Factory initial Setting:** E1=-1, E2=8, E3=6, E4=3, E5=2, E6=0, F1=25, F2=3, F3=15, F4=0, C1=0.

Please adjust E5 setting as below according to different ambient temperature range:

Ambient Temp(°C)	E5 setting	Other Setting
25 - 27	-01	NO change
22 - 24	0	NO change
19 - 21	1	NO change
15 - 18	2	NO change

**Remark:** The ambient temperature for this unit is better under 27 degree. If the ambient temperature is over 27



# Operation

degree, the units can work, but the efficiency of unit decline and the compressor is difficult to stop. The setting for over 27 degrees is same as the range of 25-27 degree.

# Maintenance

1. Cabinet cleaning: The product should be cleaned once a week with the power supply disconnected. When cleaning, use mild rinsing water and non-corrosive detergent. Do not wash it directly under the faucet.
2. De-dust the condenser to clean. The condenser should be cleaned every three months with power supply disconnected. To clean the condenser, remove the dust on the bottom panel for air suction and remove the dust on the cooling fan of the condenser with wire brush or high pressure air gun.
3. Check for any leaks as well as oil stains. This will indicate that there is repair needed, to be performed by trained personnel.
4. Frequently observe the operation of the product. In case of abnormal noise, smell or smog, cut the power supply immediately and call for a trained technician. Do not restart the product before the problem is fixed.
5. Omcan Inc. will not be responsible for any accidents that occur because of failure to follow the regular maintenance.

## SERVICE

- To maintain good refrigeration performance, a refrigeration service person should be called periodically (at least twice a year) to clean the discharge honeycomb and remove any accumulated dirt from the condenser coil and condensate evaporator pan on self-contained models. POOR CIRCULATION OF AIR THROUGH THE CONDENSER COIL WILL RESULT IN POOR REFRIGERATION PERFORMANCE.
- Dirt accumulation inside the condensate evaporator pan will reduce the pan's capacity and affect the efficiency of the heater causing a burned out heater and an overflow of defrost water onto the store floor.

# Troubleshooting

Troubles	Causes	Solutions
Strange noise under the bottom shelf.	Fan blade is broken.	Power off and fix the blade.
No refrigeration in spite of normal operation.	Unit off.	Power on.
	Defrost process.	Stop defrost cycle.
	Refrigerant leaking.	Patch the leak and refill refrigerant.
	Unit failure.	Call for professionals.

# Troubleshooting

Weak air from curtain, and higher cabinet temperature.	Evaporator blocked by frost.	Increase defrost frequency.
	Inside fan damaged.	Replace the fan.
	Too low set point of temperature controller.	Adjust the set point.
	Vent blocked by storage.	Remove the storage.
Normal air curtain, but higher cabinet temperature.	Insufficient refrigerant.	Refill the refrigerant.
	Too high set point of temperature controllers.	Adjust the set point of the temperature controller.
	The wind curtain is disturbed by strong air flow.	Removing the disturbing factors.
	Ambient temperature or humidity beyond standards.	Improve the conditions.
Evaporator Pan overflowing.	Heating pipe for evaporator pan is damaged.	Replace the heating pipe.
	Water-level controller failure.	Replace the water-level controller.
	Ambient temperature or humidity beyond standards.	Improve the conditions.
Normal air curtain but periodical fluctuation of cabinet temperature.	Condenser contaminated.	Clean the condenser.
	Poor venting of the unit.	Improve the venting conditions.
	Heat protection of compressor failure.	Replace the heat protection.
	Capillary is blocked by ice.	Replace the drying filter.
	Temperature controller failure.	Replace the temperature controller.
Water leaks on floor.	Ambient room temperature exceeds 75°F and 55% relative humidity.	Connect appliance drain to floor drain.

## NOTE

The murmur of water is heard when the refrigerator is working. The coolant is circulating in the system. During wet seasons, condensation might be found on the outside of the refrigerator. This is caused by high humidity. Use a cloth to wipe it.

## NOTE



The electric circuit diagram and parameters on the product name plate are final ones. The design of the machine may be improved without notice. If the supply cord is damaged, it must be replaced by the manufacturer, its service agent or similarly qualified persons in order to avoid hazard.

# Controller Instructions

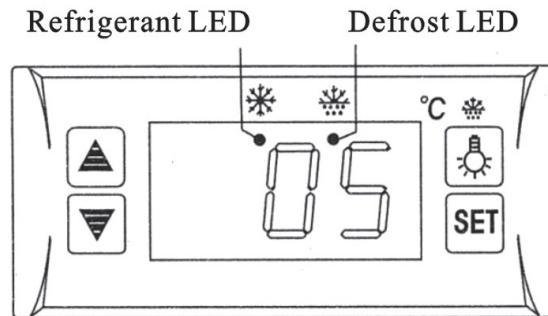
## Digital Temperature Controller



## Front Panel Operation

1. Set temperature.
  2. Press the "SET" button, the set temperature is displayed.
  3. Press ▲ or ▼ buttons to modify and store the displayed value.
  4. Press the "SET" button to exit the adjustment and display the cold-room temperature.
  5. If no more buttons are pressed within 10 seconds, the cold-room temperature will be displayed.
  6. Illumination: Press  to light. Press again to stop.
  7. Manual start/stop defrost: press  button and hold for 6 seconds to defrost or stop defrost.
  8. Refrigerant LED: During refrigeration, the LED is on; When the cold room temperature is constant, the LED is off; During the delay start, the LED flashes.
  9. Defrost LED: during defrosting, the LED is on; When it stops defrosting, the LED is off. During the delay display of defrost, the LED flashes.
- Unauthorized modifications and/or repairs;
  - Use of non original accessories or spare parts;
- Exceptional events.

## FEATURES OF FUNCTION

- This temperature controller very reliable and durable. The relay is exclusively for the use of the compressor load which makes it safer. This way, the control of temperature easy to operate.
- There is integrated intelligent control.

## THE MAIN FEATURES

- Temperature display (Celsius/Fahrenheit degrees).
- Temperature control.
- Illumination control.
- Manual, automatic defrost by turning off.
- Time or temperature setting to end defrost.

# Controller Instructions

---

- The cold-room sensor temperature can lock during defrost.
- Parameter sets and value storing.
- Compressor restart delay.
- Parameter locking.
- The factory default resumption.
- Offset on sensor temperature.
- Self-testing.

## SPECIFICATIONS

- Power supply: approx. 12V, 50/60Hz.
- Power consumption <5W.
- Range of temperature displayed: -45° - 45°C (-40° - 120°F). Accuracy  $\pm 1^{\circ}\text{C}$  ( $\pm 2^{\circ}\text{F}$ ).
- Range of set temperature: -45° - 45°C (-40° - 120°F).
- Temperature sensor: NTC, double sensors.
- Output contact capacity for compressor: N.O. approx. 30A/250V, 50/60Hz.
- Output contact capacity for illumination: N.O. approx. 30A/250V, 50/60Hz.
- Main controller panel dimension: 78 x 35 x 76 mm.
- Mounting dimension: 71 x 29 mm.

## INDICATOR

- Refrigerant: If the refrigerant LED is on, the compressor is working.
- Constant temperature: If the refrigerant LED is off, the compressor stops.
- Delay: If the refrigerant LED flashes, the compressor stops.
- Defrost: If the defrost LED is on, the compressor stops.

## FRONT PANEL OPERATION

- Set temperature: Press "SET" button, the set temperature is displayed. Press the "UP" or "DOWN" buttons to modify and store the displayed value, press the "SET" button to exit the menu and display the cold-room temperature.
- Illumination: Press the "LIGHT" button, it lights. Press again, it stops.
- Manual start/stop defrost: Press "LIGHT" button and hold for six (6) seconds to defrost or stop defrost.
- Display the evaporator temperature: Press "UP" button and hold for six (6) seconds, the evaporator temperature is displayed. After ten (10) seconds, the cold-room temperature is displayed.

## PARAMETER SETUP

- Setting the parameter: The parameter can be adjusted only after correct PA is entered. If wrong, the parameter can only be checked, but cannot be adjusted. However temperature controlling can still occur.
- Setting parameter: Press "SET" for six (6) seconds, start the parameter menu and the PA (menu password) flashing. Enter the password by pressing "UP" or "DOWN". Press "SET" again to choose the parameter. Press "UP" or "DOWN" and the parameter can be displayed and adjusted. After the change, if no button is pressed in thirty (30) seconds, the system will set new parameter and go back to normal operations.

# Controller Instructions

- Changing menu password (CPA): The CPA can be checked or changed only after correct menu password to be entered. When it shows CPA, press “UP” or “DOWN”, the present password is displayed and can be changed to new the new password. Press “LIGHT” to confirm and apply the new password. (Make sure to remember the new password or you can never adjust another parameter).
- Setting factory default parameters: Press “DOWN” button for one (1) second and then press “UP” button simultaneously for six (6) seconds, the indicator flashes. All parameters will be changed to factory defaults. After ten (10) seconds, it returns to normal operation.

## FUNCTION DETAILS

Parameter	Function	Set Range	Default Settings	Recommended Settings
PA	Menu Password	Approx. 0 – 99	00°	00°
E1	Lower Set Point	Approx. -45°C Set Temperature Approx. -40°F	-15°C 05°F	-5°
E2	Higher Set Point	Set Temperature Approx. 45°C Approx. 120°F	10°C 50°F	6°
E3	Temperature Hysteresis	Approx. 00 – 10°C Approx. 1 – 36°F	05°C 07°C	4°
E4	Compressor Start Delay	Approx. 00 – 10 minutes	00°	0°
E5	Offset On Room Temperature	Approx. -5°C - 5°C / F	00°	-1°
E6	Offset On Evaporator Temperature	Approx. -5°C - 5°C / F	00°	0°
F1	Maximum Defrost Duration	Approx. 1 – 60 minutes	20°	25°
F2	Defrost Interval Time	Approx. 00 – 24 hours	06°	4°
F3	Defrost Termination Temperature	Approx. 0 – 20°C Approx. 32°F - 68°F	12°C 54°F	20°
F4	Display During Defrost	00 = normal display 01 = Last value before defrost	01°	0°
C1	Temperature Unit	00 = °C 01 = °F	00°	0°
CPA	Changing Menu Password	Approx. 00 – 90 (Setting “00”, the menu password is cancelled).	00°	0°

### Notes:

- The parameters can be changed only after the correct PA is entered, or else it can only be checked. Temperature controlling can be changed without the correct PA.
- PA is set “00”, no password required for checking and/or changing.

# Controller Instructions

---

## PARAMETER DETAILS

- Temperature controlling: After turning on for the delay time (E4), the compressor starts operating when cold-room temperature is greater than the set temperature (set temperature + hysteresis), and will be off when cold-room temperature less than the set temperature. To protect the compressor, it can be restarted, unless the time when the compressor stops is longer than the delay time (E4).
- Defrost by turning off: After a defrost interval, it begins automatic defrost function. Eg: When evaporator sensor temperature is less than the defrost termination temperature (F3), the defrost LED is on and the compressor stops. When evaporator sensor is greater than the defrost termination temperature or defrost duration (F1) the defrost stops. After two (2) minutes of draining time, the cold-room temperature is greater than (set temperature + hysteresis) and the compressor starts. It goes back to refrigeration status. When defrost interval time (F2) is set "00", the function of automatic defrost will be cancelled. Temperature displayed when defrost: If F4 is set "01", it displays the temperature when defrost starts. After defrost, it will continue to display this temperature for twenty (20) minutes and the defrost LED flashes, then come back to normal temperature.
- Sensory work mode: If the cold-room sensor is short circuited or overheated, "HH" is displayed. If the cold-room sensory has an open circuit or too low temperature, "LL" is displayed. The compressor automatically has a cycle of forty-five (45) minutes on and fifteen (15) minutes off. When the evaporator sensor fails or it is over the displayed range, the defrost termination will be just controlled by the defrost duration.

## NOTES FOR INSTALLATION

- Before wiring, please read the instructions carefully and understand the function of every contact so that you can make correct wire connection. Control loads cannot exceed the ratings.
- The temperature controller cannot be installed any area where there is water, dirt, moisture or high temperatures. Please pay attention to EMC problem and prevent the temperature controller from any potentially dangerous contact.
- The sensor cable leads must be kept away from the main supply in order to avoid a high frequency noise. 0.75 – 1.5 mm<sup>2</sup> flexible cord shall be used for wiring control load terminals.
- The evaporator sensor must be installed between the fins of the evaporator in the area, where there is the thickest ice. Do not place the evaporator sensor near the electric heater.
- If the temperature controller stops functioning, please cut off the power supply and reset.
- Please don't dismantle the controller. If you need to repair or if there any problems when using the controller, contact an authorized service center.

# Parts Breakdown

Model RS-CN-0250 25825

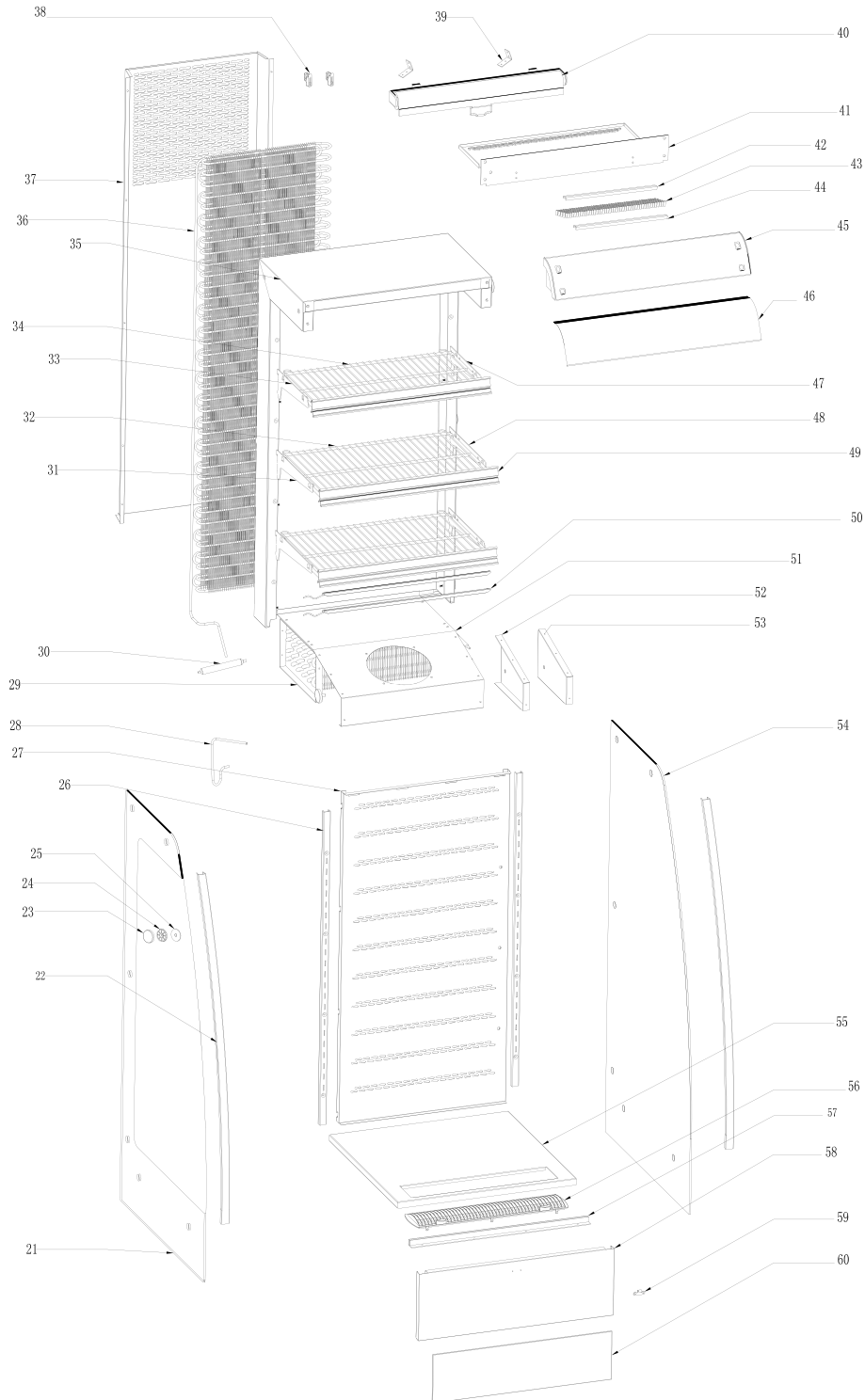

# Parts Breakdown

Model RS-CN-0250 25825

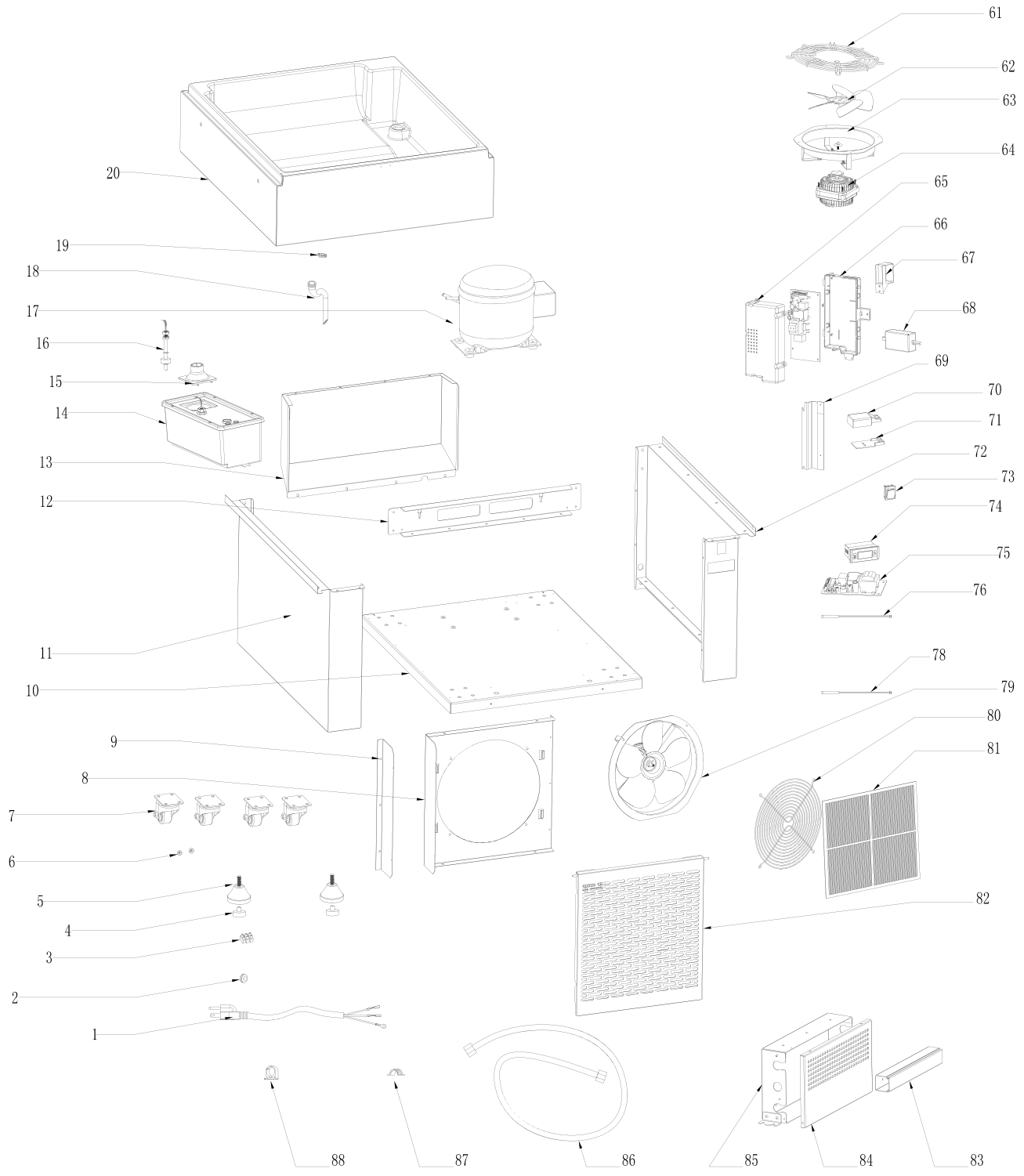





# Parts Breakdown

## Model RS-CN-0250 25825

Item No.	Description	Position	Item No.	Description	Position	Item No.	Description	Position
79290	Power Cord for 25825	1	60577	Dry Filter for 25825	30	60651	Curtain Hook for 25825	59
79291	Wire Clip for 25825	2	30747	Left Shelf Bracket for 25825	31	79349	Glass Deflector for 25825	60
79292	Terminal for 25825	3	79321	Bottom Shelf for 25825	32	AF543	Flat Net Cover for 25825	61
79293	Feet Pad for 25825	4	79322	Left Shelf Bracket for 25825	33	71565	Fan Blade for 25825	62
79294	Feet for 25825	5	79323	Top Shelf for 25825	34	71564	Fan Guard for 25825	63
79295	Magnet for 25825	6	79324	Foam of Back Cover for 25825	35	71522	Evaporator Fan Motor for 25825	64
60561	Rear Wheels for 25825	7	AF538	Condenser for 25825	36	60594	Cover of Circuit Board Box for 25825	65
79297	Holder for Condenser Motor for 25825	8	79326	Condenser Cover for 25825	37	61167	Circuit Board Box for 25825	66
79298	Condenser Motor Bracket Guard for 25825	9	61222	Stands for Condenser for 25825	38	79356	LED Transformer Holder for 25825	67
79299	Base Board for 25825	10	AF539	Night Curtain Bracket for 25825	39	67652	LED Transformer for 25825	68
79300	Left Panel of Base for 25825	11	AD502	Night Curtain for 25825	40	AF544	Bracket of Circuit Board Box for 25825	69
79301	Crossbar of Base for 25825	12	79330	Air-Out Board for 25825	41	79359	Cover of Junction Box for 25825	70
AF537	Back Cover of Base for 25825	13	79331	Back Clamp for 25825	42	61244	Junction Box for 25825	71
60587	Water Receiver for 25825	14	79332	Honeycomb Panel for 25825	43	79361	Right Panel of Base for 25825	72
79304	Pipe for Evaporated Water for 25825	15	79333	Front Clamp for 25825	44	71514	Switch for 25825	73
60589	Water Level Detector for 25825	16	AF540	Top Front Cover for 25825	45	AF545	Temperature Display for 25825	74
AD521	Compressor for 25825	17	AF541	Decorative Board for 25825	46	AF546	Main Circuit Board for 25825	75
30744	Water Pipe for 25825	18	79336	Right Shelf Bracket for 25825	47	60666	Temperature Probe for 25825	76
68368	Snap Ring for 25825	19	30750	Right Shelf Bracket for 25825	48	AD481	Overheating Probe for 25825	78
79309	Base Foam for Evaporator for 25825	20	79338	Price Tag Holder for 25825	49	79364	Condenser Fan Motor for 25825	79
79310	Left Glass for 25825	21	AF542	Shelf LED Light for 25825	50	79367	Flat Net Cover for 25825	80
79311	Front Decorative Strip for 25825	22	68310	Fixed Plate of Evaporator Motor for 25825	51	79368	Air Filter for 25825	81
79312	Nut Decoration for 25825	23	68309	Right Fixed Plate of Evaporator Motor for 25825	52	79369	Ventilated Board of Base for 25825	82
79313	Nut Gasket for 25825	24	68334	Right Fixed Plate of Evaporator Motor for 25825	53	60590	PVC Trucking for 25825	83
79314	Decoration Nut Gasket for 25825	25	79343	Right Glass for 25825	54	67642	Cover of Terminal Box for 25825	84
79315	Pole for Shelf for 25825	26	79344	Bottom Frame of Cabinet for 25825	55	67643	Terminal Box for 25825	85
79316	Ventilated Board for 25825	27	79345	Air Intake Grill for 25825	56	60668	Drain Pipe for 25825	86
61234	Connection Pipe for 25825	28	79346	Wind Screen Strip for 25825	57	60669	Pipe Clamp for 25825	87
71562	Evaporator for 25825	29	79347	Front Decorative Board for 25825	58	60670	PPR Pipe Clamp for 25825	88

# Electrical Schematics

Model RS-CN-0250 25825

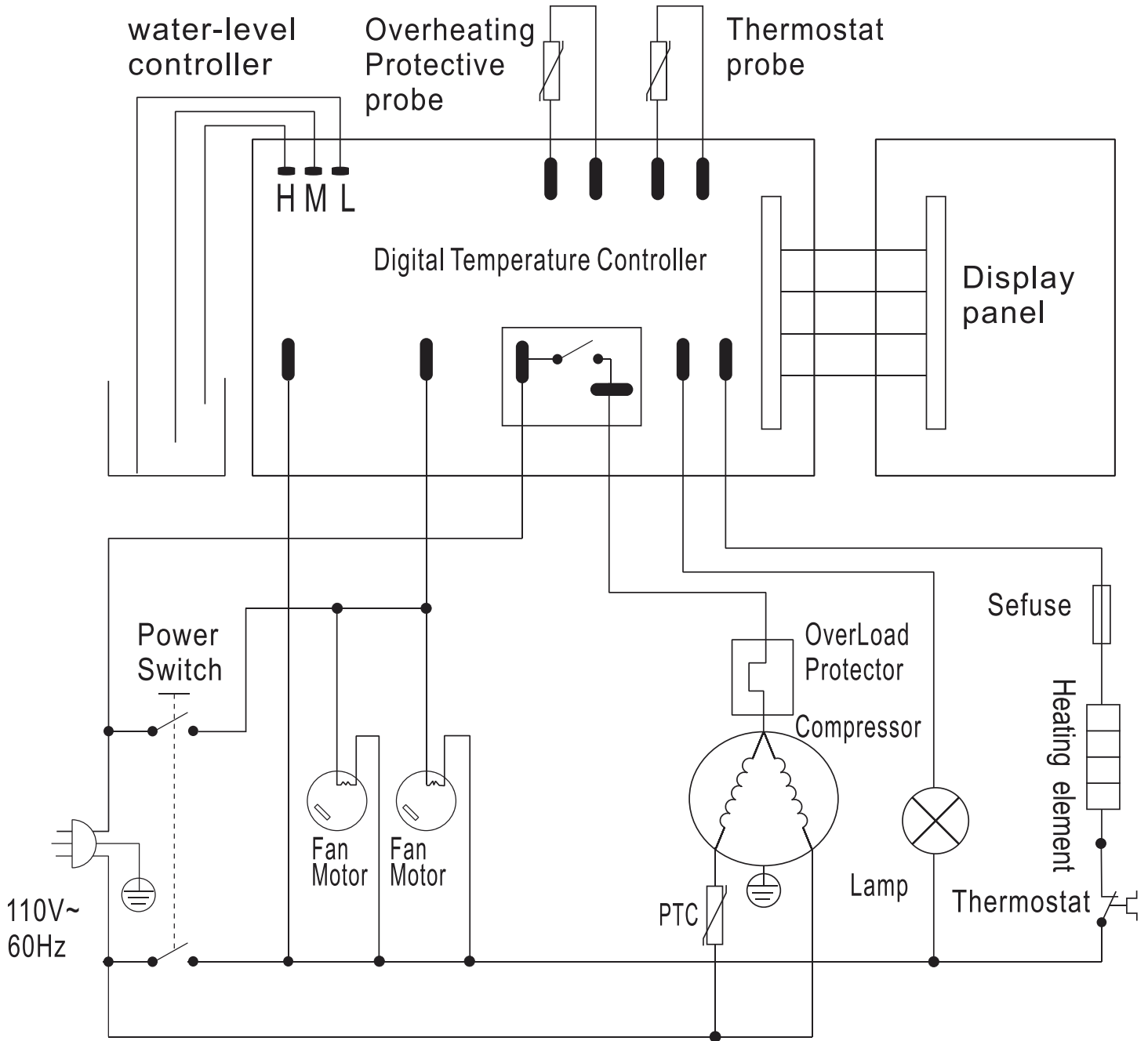



# Warranty Registration

Thank you for purchasing an Omcan product. To register your warranty for this product, complete the information below, tear off the card at the perforation and then send to the address specified below. You can also register online by visiting:

Merci d'avoir acheté un produit Omcan. Pour enregistrer votre garantie pour ce produit, complétez les informations ci-dessous, détachez la carte au niveau de la perforation, puis l'envoyer à l'adresse spécifiée ci-dessous. Vous pouvez également vous inscrire en ligne en visitant:

Gracias por comprar un producto Omcan usted. Para registrar su garantía para este producto, complete la información a continuación, cortar la tarjeta en la perforación y luego enviarlo a la dirección indicada a continuación. También puede registrarse en línea en:

<https://omcan.com/warranty-registration/>

For mailing in Canada

Pour postale au Canada

Por correo en Canadá

**OMCAN**

PRODUCT WARRANTY REGISTRATION

3115 Pepper Mill Court,

Mississauga, Ontario

Canada, L5L 4X5

For mailing in the US

Pour diffusion aux États-Unis

Por correo en los EE.UU.

**OMCAN**

PRODUCT WARRANTY REGISTRATION

4450 Witmer Industrial Estates, Unit 4,

Niagara Falls, New York

USA, 14305

*or email to: [service@omcan.com](mailto:service@omcan.com)*



Purchaser's Information

Name: \_\_\_\_\_

Address: \_\_\_\_\_

City: \_\_\_\_\_ Province or State: \_\_\_\_\_ Postal or Zip: \_\_\_\_\_

Country: \_\_\_\_\_

Dealer from which Purchased: \_\_\_\_\_

Dealer City: \_\_\_\_\_ Dealer Province or State: \_\_\_\_\_

Invoice: \_\_\_\_\_

Model Name: \_\_\_\_\_ Model Number: \_\_\_\_\_

Machine Description: \_\_\_\_\_

Date of Purchase (MM/DD/YYYY): \_\_\_\_\_

Would you like to extend the warranty?  Yes  No

Company Name: \_\_\_\_\_

Telephone: \_\_\_\_\_

Email Address: \_\_\_\_\_

Type of Company:

Restaurant  Bakery  Deli

Butcher  Supermarket  Caterer

Institution (specify): \_\_\_\_\_

Other (specify): \_\_\_\_\_

Serial Number: \_\_\_\_\_

Date of Installation (MM/DD/YYYY): \_\_\_\_\_

**Thank you for choosing Omcan | Merci d'avoir choisi Omcan | Gracias por elegir Omcan**



Since 1951 Omcan has grown to become a leading distributor of equipment and supplies to the North American food service industry. Our success over these many years can be attributed to our commitment to strengthen and develop new and existing relationships with our valued customers and manufacturers. Today with partners in North America, Europe, Asia and South America, we continually work to improve and grow the company. We strive to offer customers exceptional value through our qualified local sales and service representatives who provide convenient access to over 6,500 globally sourced products.

---

Depuis 1951 Omcan a grandi pour devenir un des “leaders” de la distribution des équipements et matériel pour l’industrie des services alimentaires en Amérique du Nord. Notre succès au cours de ces nombreuses années peut être attribué à notre engagement à renforcer et à développer de nouvelles et existantes relations avec nos clients et les fabricants de valeur. Aujourd’hui avec des partenaires en Amérique du Nord, Europe, Asie et Amérique du Sud, nous travaillons continuellement à améliorer et développer l’entreprise. Nous nous efforçons d’offrir à nos clients une valeur exceptionnelle grâce à nos ventes locales qualifiées et des représentants de service qui offrent un accès facile à plus de 6500 produits provenant du monde entier.

---

Desde 1951 Omcan ha crecido hasta convertirse en un líder en la distribución de equipos y suministros de alimentos en América del Norte industria de servicios. Nuestro éxito en estos años se puede atribuir a nuestro compromiso de fortalecer y desarrollar nuevas relaciones existentes con nuestros valiosos clientes y fabricantes. Hoy con socios de América del Norte, Europa, Asia y América del Sur, que trabajan continuamente para mejorar y crecer la empresa. Nos esforzamos por ofrecer a nuestros clientes valor excepcional a través de nuestro local de ventas y representantes de los servicios que proporcionan un fácil acceso a más de 6,500 productos con origen a nivel mundial.

