

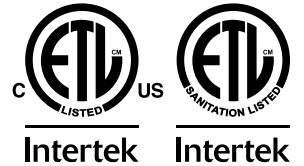

**Refrigerated Showcase**  
*Model RS-CN-0500*  
*Item 34874*  
**Instruction Manual**



*Revised - 05/02/2023*



---

Toll Free: 1-800-465-0234  
Fax: 905-607-0234  
Email: [service@omcan.com](mailto:service@omcan.com)  
[www.omcan.com](http://www.omcan.com)



# ***Table of Contents***

Model RS-CN-0500

---

<b>Section</b>	<b>Page</b>
Disclaimer -----	3
General Information -----	4 - 5
Safety and Warranty -----	5 - 7
Technical Specifications -----	7
Operation -----	8 - 9
Maintenance -----	9
Troubleshooting -----	9 - 10
Parts Breakdown -----	11 - 12
Electrical Schematics -----	13
Notes -----	14
Warranty Registration -----	15

## ***Disclaimer***

---

***OMCAN IS NOT RESPONSIBLE FOR ANY DAMAGES DUE TO WATER LEAKS. WARRANTY FOR WATER LEAKS IS VOID IF THE AMBIENT ROOM TEMPERATURE EXCEEDS 75°F AND 55% RELATIVE HUMIDITY, AND THE APPLIANCE DRAIN IS NOT CONNECTED DIRECTLY TO A FLOOR DRAIN.***

---

***OMCAN N'EST PAS RESPONSABLE DES DOMMAGES DUS AUX FUITES D'EAU. LA GARANTIE POUR LES FUITES D'EAU EST ANNULÉE SI LA TEMPÉRATURE AMBIANTE DE LA PIÈCE DÉPASSE 75°F ET 55% D'HUMIDITÉ RELATIVE, ET SI LE DRAIN DE L'APPAREIL N'EST PAS RACCORDÉ DIRECTEMENT À UN DRAIN DE PLANCHER.***

---

***OMCAN NO SE HACE RESPONSABLE DE LOS DAÑOS CAUSADOS POR FUGAS DE AGUA. LA GARANTÍA POR FUGAS DE AGUA QUEDA ANULADA SI LA TEMPERATURA AMBIENTE SUPERA LOS 75°F Y EL 55% DE HUMEDAD RELATIVA, Y EL DESAGÜE DEL APARATO NO ESTÁ CONECTADO DIRECTAMENTE A UN DESAGÜE DE PISO.***

# ***General Information***

---

**Omcan Manufacturing and Distributing Company Inc., Food Machinery of America, Inc. dba Omcan and Omcan Inc. are not responsible for any harm or injury caused due to any person's improper or negligent use of this equipment. The product shall only be operated by someone over the age of 18, of sound mind, and not under the influence of any drugs or alcohol, who has been trained in the correct operation of this machine, and is wearing authorized, proper safety clothing. Any modification to the machine voids any warranty, and may cause harm to individuals using the machine or in the vicinity of the machine while in operation.**

## **CHECK PACKAGE UPON ARRIVAL**

Upon receipt of an Omcan shipment please inspect for external damage. If no damage is evident on the external packaging, open carton to ensure all ordered items are within the box, and there is no concealed damage to the machine. If the package has suffered rough handling, bumps or damage (visible or concealed), please note it on the bill of lading before accepting the delivery and contact Omcan within 24 hours, so we may initiate a claim with the carrier. A detailed report on the extent of the damage caused to the machine must be filled out within three days, from the delivery date shown in the shipping documents. Omcan has no recourse for damaged products that were shipped collect or third party.

**Before operating any equipment, always read and familiarize yourself with all operation and safety instructions.**

**Omcan would like to thank you for purchasing this machine. It's of the utmost importance to save these instructions for future reference. Also save the original box and packaging for shipping the equipment if servicing or returning of the machine is required.**

---

**Omcan Fabrication et distribution Compagnie Limitée et Food Machinery d'Amérique, dba Omcan et Omcan Inc. ne sont pas responsables de tout dommage ou blessure causé du fait que toute personne ait utilisé cet équipement de façon irrégulière. Le produit ne doit être exploité que par quelqu'un de plus de 18 ans, sain d'esprit, et pas sous l'influence d'une drogue ou d'alcool, qui a été formé pour utiliser cette machine correctement, et est vêtu de vêtements de sécurité appropriés. Toute modification de la machine annule toute garantie, et peut causer un préjudice à des personnes utilisant la machine ou des personnes à proximité de la machine pendant son fonctionnement.**

## **VÉRIFIEZ LE COLIS DÈS RÉCEPTION**

Dès réception d'une expédition d'Omcan veuillez inspecter pour dommages externes. Si aucun dommage n'est visible sur l'emballage externe, ouvrez le carton afin de s'assurer que tous les éléments commandés sont dans la boîte, et il n'y a aucun dommage dissimulé à la machine. Si le colis n'a subi aucune mauvaises manipulations, de bosses ou de dommages (visible ou cachée), notez-le sur le bond de livraison avant d'accepter la livraison et contactez Omcan dans les 24 heures qui suivent, pour que nous puissions engager une réclamation auprès du transporteur. Un rapport détaillé sur l'étendue des dommages causés à la machine doit être rempli dans un délai de trois jours, à compter de la date de livraison indiquée dans les documents d'expédition. Omcan n'a aucun droit de recours pour les produits endommagés qui ont été expédiés ou cueilli par un tiers transporteur.



# General Information

---

Avant d'utiliser n'importe quel équipement, toujours lire et vous familiariser avec toutes les opérations et les consignes de sécurité.

Omcan voudrais vous remercier d'avoir choisi cette machine. Il est primordial de conserver ces instructions pour une référence ultérieure. Également conservez la boîte originale et l'emballage pour l'expédition de l'équipement si l'entretien ou le retour de la machine est nécessaire.

Omcan Empresa De Fabricacion Y Distribucion Inc. Y Maquinaria De Alimentos De America, Inc. dba Omcan y Omcan Inc. no son responsables de ningun daño o perjuicio causado por cualquier persona inadecuada o el uso descuidado de este equipo. El producto solo podra ser operado por una persona mayor de 18 años, en su sano juicio y no bajo alguna influencia de droga o alcohol, y que este ha sido entrenado en el correcto funcionamiento de esta máquina, y ésta usando ropa apropiada y autorizada. Cualquier modificación a la máquina anula la garantía y puede causar daños a las personas usando la máquina mientras esta en el funcionamiento.

## REVISE EL PAQUETE A SU LLEGADA

Tras la recepcion de un envio Omcan favor inspeccionar daños externos. Si no hay daños evidentes en el empaque exterior, Habra el carton para asegurarse que todos los articulos solicitados estén dentro de la caja y no encuentre daños ocultos en la máquina. Si el paquete ha sufrido un manejo de poco cuidado, golpes o daños (visible o oculto) por favor anote en la factura antes de aceptar la entrega y contacte Omcan dentro de las 24 horas, de modo que podamos iniciar una reclamación con la compañía. Un informe detallado sobre los daños causados a la máquina debe ser llenado en el plazo de tres días, desde la fecha de entrega que se muestra en los documentos de envío. Omcan no tiene ningun recurso por productos dañados que se enviaron a recoger por terceros.

Antes de utilizar cualquier equipo, siempre lea y familiarizarse con todas las instrucciones de funcionamiento y seguridad.

Omcan le gustaría darle las gracias por la compra de esta máquina. Es de la mayor importancia para salvar estas instrucciones para futuras consultas. Además, guarda la caja original y el embalaje para el envío del equipo si servicio técnico o devolución de la máquina que se requiere.

# Safety and Warranty

---

## HANDLING AND INSTALLATION

<b>Handle with care</b> Unplug from the wall socket before moving. Never tilt the refrigerator over 45 degrees during handling.	<b>Storage</b> Always store the refrigerator in a dry place.
--	---

# Safety and Warranty

<p><b>Sufficient space</b> To allow for proper air circulation and increased refrigeration capabilities, the refrigerator must have at least 4"/10cm of space between wall/ceiling and the machine.</p>	<p><b>Proper ventilation</b> Always place the refrigerator in an area with good ventilation. For first time use, set in location and wait at least 2 hours before plugging into wall socket.</p>
<p><b>Away from heat source</b> Never place the refrigerator near any type of heat source or in direct sunlight, as it reduces refrigeration capabilities.</p>	<p><b>No heavy load</b> Never put heavy items on top of the refrigerator.</p>
<p><b>No altercations/tampering</b> Never tamper with or make changes to the refrigerator. Changes and add-ons should not be installed to the inside or outside of the refrigerator.</p>	<p><b>Stable location</b> Unpack and place the refrigerator on flat, solid ground.</p>

## PREPARATION AND POWER SUPPLY

<p><b>Exclusive power outlet</b> Power supply should be 110-120V, single phase AC with exclusive single phase three pin outlet (125V/15A). The power outlet must be in close proximity to the ground.</p>	<p><b>No shared power outlets</b> Refrigerator cable should never share the power outlet with any other appliance, as cable will overheat and may result in a fire.</p>
<p><b>Protect cables</b> Extra caution should be used when handling cables, as broken or damaged cables can cause sparking and may result in a fire.</p>	<p><b>No water flushing</b> Never flush the refrigerator surface. This can cause leakage, which may result in electrical damage or fire.</p>
<p><b>Never store flammables and explosives</b> No explosives or flammables should be stored in, or in proximity to, the refrigerator, such as gasoline, alcohol, and adhesives.</p>	<p><b>No spray</b> Never spray flammables such as paint or coating near the refrigerator. This may cause fire or malfunction.</p>
<p><b>After power outage</b> After a power outage or the unplugging of the refrigerator, wait at least 5 minutes before plugging it back in.</p>	<p><b>No medicine</b> Medicine should not be stored inside of the refrigerator.</p>

**RESIDENTIAL USERS:** Vendor assumes no liability for parts or labor coverage for component failure or other damages resulting from installation in non-commercial or residential applications. The right is reserved to deny shipment for residential usage; if this occurs, you will be notified as soon as possible.

## 1 YEAR PARTS AND LABOUR WARRANTY

Within the warranty period, contact Omcan Inc. at 1-800-465-0234 to schedule an Omcan authorized service technician to repair the equipment locally.



# Safety and Warranty

Unauthorized maintenance will void the warranty. Warranty covers electrical and part failures not improper use.

Please see <https://omcan.com/disclaimer> for complete info.

## WARNING:

The packaging components are classified as normal solid urban waste and can therefore be disposed of without difficulty.

In any case, for suitable recycling, we suggest disposing of the products separately (differentiated waste) according to the current norms.

**DO NOT DISCARD ANY PACKAGING MATERIALS IN THE ENVIRONMENT!**

# Technical Specifications

<b>Model</b>	<b>RS-CN-0500</b>
<b>Power</b>	0.36 kW
<b>Capacity</b>	500 L / 17.65 cu.ft.
<b>Electrical</b>	110-120V / 60Hz / 1
<b>Lamp Power</b>	12W (LED)
<b>Temperature Range</b>	0 - 12°C / 32 - 53.6°F
<b>Max Ambient Temp Rating</b>	24°C / 75°F
<b>Refrigerant and Injection</b>	R290
<b>Rated Current</b>	3.3A
<b>Shelf Size</b>	22.6" x 22" / 575 x 559mm
<b>Dimensions</b>	25.6" x 25.6" x 76.6" / 650 x 650 x 1945mm
<b>Weight</b>	297 lbs. / 134.7 kgs.
<b>Packaging Dimensions</b>	30" x 29" x 85" / 762 x 737 x 2159mm
<b>Packaging Weight</b>	317 lbs. / 143.8 kgs.
<b>Item Number</b>	34874

# Operation

## BEFORE USE

- Plug refrigerator into the 110-120V exclusive socket.
- After the refrigerator is running, confirm that air suction/filtration is in working order and that it is sufficiently cold. After checking to make sure the refrigerator is working properly, it may be used.

## DIGITAL TEMPERATURE CONTROLLER

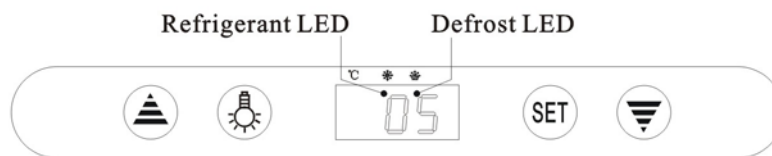

## FEATURES OF FUNCTION

- Small, integrated digital controller, which is applicable to the compressor of 1 Hp. Located behind the front grill.
- Main functions are: Temperature Display/Temperature Control/Manual-Automatic /Light Control/Value Storing/Self-Testing/Parameter Locking.

## FRONT PANEL OPERATION

1. Set temperature: Press **SET** button; set temperature will be displayed. Press **▲** or **▼** button to modify and store the displayed value. Press **SET** button to exit the adjustment and display the cold-room temperature.
2. If no button is pressed within 10 seconds, the cold-room temperature will be displayed.
3. Lighting: Press **☹** button to activate light in refrigerator; press again to turn off. Manual start/stop defrost: Press **☹** button and hold for 6 seconds to either defrost or to stop defrost.
4. Refrigeration LED: During refrigeration, the LED is on. When the cold room temperature is constant, the LED is off. During delay start, the LED flashes.
5. Defrost LED: During defrosting, the LED is on. When it stops defrosting, the LED is off. During the delay of defrost, the LED flashed.

## CAUTION

- Never block the air outlet and suction to keep the air circulation and refrigeration capability constant.
- Do not overfill refrigerator with food, as it will influence the cooling effect. If needed, adjust the rack height for proper food storage.
- Cool down hot food to room temperature before placing inside the refrigerator.
- When power supply has been cut off, reduce opening times and maintain cool temperature in refrigerator.
- To avoid scalding, never touch the compressor.
- If the supply cord is damaged, it must be replaced by the manufacturer, its service agent, or similarly qualified persons in order to avoid hazard.
- This appliance is not intended for use by persons (including children) with reduced physical, sensory or



# Operation

mental capabilities, or lack of experience and knowledge, unless they have been given supervision or instruction concerning use of the appliance by a person responsible for their safety.

- Children should be supervised to ensure that they do not play with the appliance.

# Maintenance

1. Cabinet Cleaning:
  - a. The product should be maintained and cleaned periodically with power supply disconnected. In cleaning, please use mild-rinsing water or non-corrosive products. Do not wash directly with water faucet.
  - b. Clean outside of unit using a soft cloth with neutral detergent, and dry with a separate soft cloth.
  - c. Clean inside racks by removing them from the unit and clean with water.
2. When shutting down unit for a long period of time, take out all food and unplug wall socket. Clean inside and outside thoroughly, and keep door open to sufficiently dry.
3. As glass breaks easily, keep far away from children.
4. Frequently observe the operation of the product. In case of any abnormal noise or smell, cut off the power supply immediately and call professionals. Do not restart the product before source of trouble is found.
5. We will not be responsible for any accidents acquired through failure to follow previous notices.

# Troubleshooting

Trouble	Causes	Solutions
Strange noise under the bottom shelf.	Fan blade broken.	Power off and fix the blade.
Non-refrigerating in spite of normal operation.	Unit off.	Power on.
	Melting process.	Stop melting.
	Refrigerant leaking.	Patch the leak and refill refrigerant.
	Unit failure.	Call Omcan.
Weak air from air curtain, and higher cabinet temperature.	Evaporator blocked by frost.	Increase melting frequency.
	Inside fan damaged.	Replace the fan.
	Too low point of temperature controller.	Adjust the set point.
	Vent blocked by storage.	Remove the storage.

# Troubleshooting

Normal air curtain, but higher cabinet temperature.	Insufficient refrigerant.	Refill the refrigerant.
	Too high set point of temperature controllers.	Adjust the set point for the temperature controller.
	The wind curtain disturbed by strong air flow.	Removing the disturbing factors.
	Ambient temperature or humidity beyond standards.	Improve the conditions.
Melting water overflows.	Heating pipe for melting water damaged.	Replace the heating pipe.
	Water level controller failure.	Replace the water level controller.
	Ambient temperature or humidity beyond standards.	Improve the conditions.
Normal air curtain, but periodical fluctuation of cabinet temperature.	Condenser contaminated.	Clean the condenser.
	Poor venting of the unit.	Improve the venting conditions.
	Heat protection of compressor failure.	Replace the heat protection.
	Capillary is blocked by ice.	Replace the drying filter.
	Temperature controller failure.	Replace the temperature controller.

## NOTE

### Following occurrences are not problems:

- The murmur of water is heard when the refrigerator is working. It is a normal occurrence as the coolant is circulating in the system.
- When the weather is damp, condensation might be found on the outside of the refrigerator. It is caused by high humidity. Simply use cloth to wipe it off.

# Parts Breakdown

Model RS-CN-0500 34874

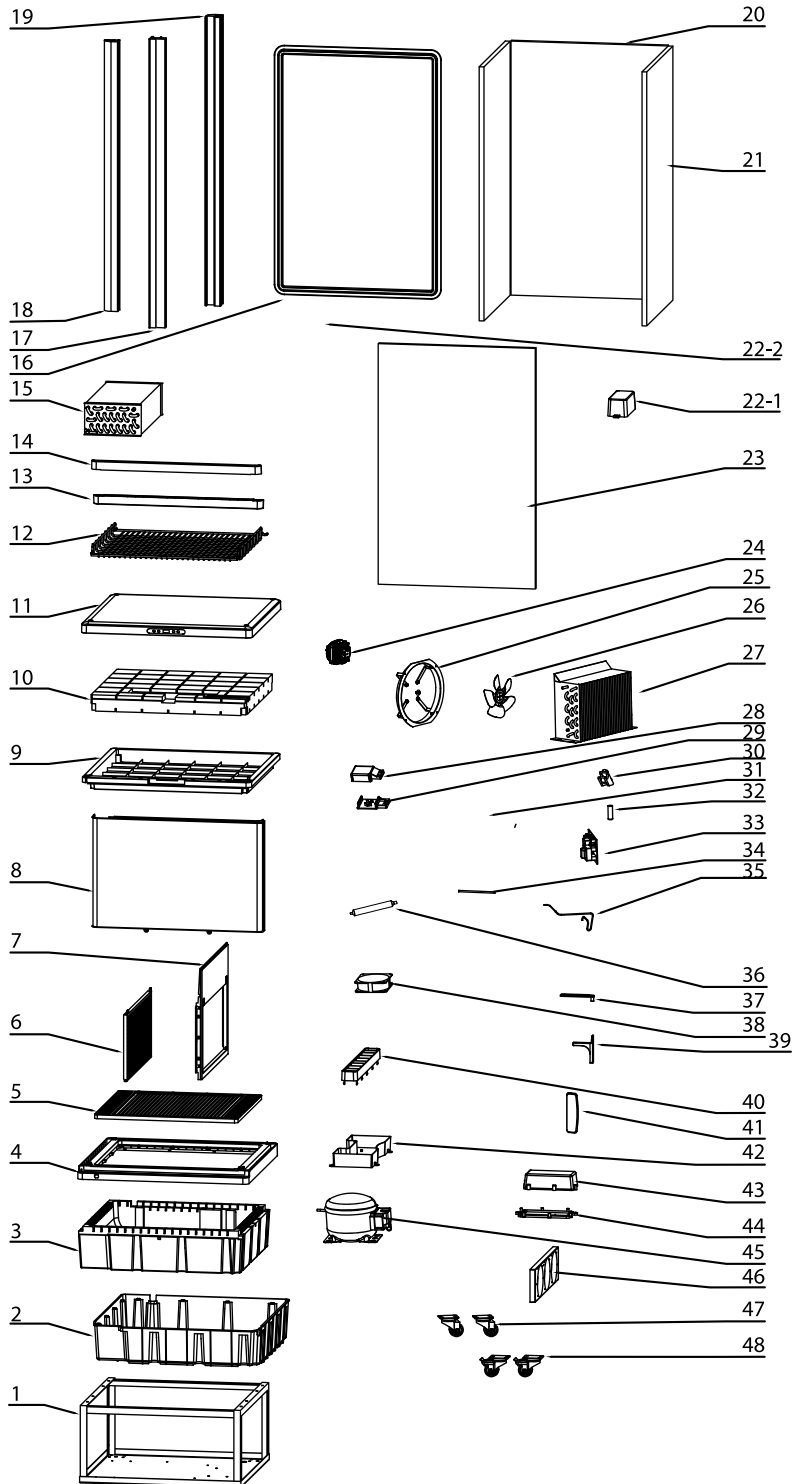

# Parts Breakdown

## Model RS-CN-0500 34874

Item No.	Description	Position	Item No.	Description	Position	Item No.	Description	Position
60908	Base for 34874	1	60925	Left and Right Door Frame for 34874	18	60143	Filling Pipe for 34874	34
60909	Plastic Base of Evaporator for 34874	2	60926	Rear Pole for 34874	19	60941	Evaporator Pipe for 34874	35
60910	Foam Base for Evaporator for 34874	3	60927	Rear Glass for 34874	20	79319	Dry Filter for 34874	36
60911	Inner Ventilated Tray for 34874	4	60928	Side Glass for 34874	21	30587	Upper Gemel for 34874	37
60912	Outer Ventilated Tray for 34874	5	60595	LED Transformer for 34874	22-1	60944	Motor of Evaporator for 34874	38
60913	Inner Enclosure Frame for 34874	6	60929	LED Light for 34874	22-2	60945	Stiffener for 34874	39
60914	Outer Enclosure Frame for 34874	7	60930	Door Glass for 34874	23	60946	Air Outlet Cover for 34874	40
60915	Rear Grill for 34874	8	60931	Motor of Evaporator for 34874	24	60947	Door Handle for 34874	41
60916	Light Ceiling for 34874	9	60932	Flange for 34874	25	60948	Water Receiver for 34874	42
60917	Foam of Light Ceiling for 34874	10	60933	Fan Blade of Condenser for 34874	26	60137	Controller Box for 34874	43
60918	Outer Plastic Panel for 34874	11	60934	Condenser for 34874	27	60136	Controller Panel for 34874	44
AC195	Shelf for 34874	12	79359	Cover of Junction Box for 34874	28	60949	Compressor for 34874	45
60920	Bottom Door Frame for 34874	13	61244	Junction Box for 34874	29	60950	Motor Bracket for 34874	46
60921	Upper Door Frame for 34874	14	45107	Shelf Clips for 34874	30	60561	Rear Wheels for 34874	47
60922	Evaporator for 34874	15	79290	Power Cord for 34874	31	60562	Front Wheels for 34874	48
60923	Door Gasket for 34874	16	30606	Door Pin for 34874	32			
60924	Front Poles of Shelves for 34874	17	60939	Digital Controller for 34874	33			

# Electrical Schematics

**Model RS-CN-0500** 34874

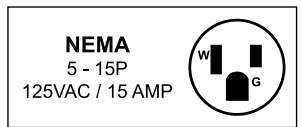
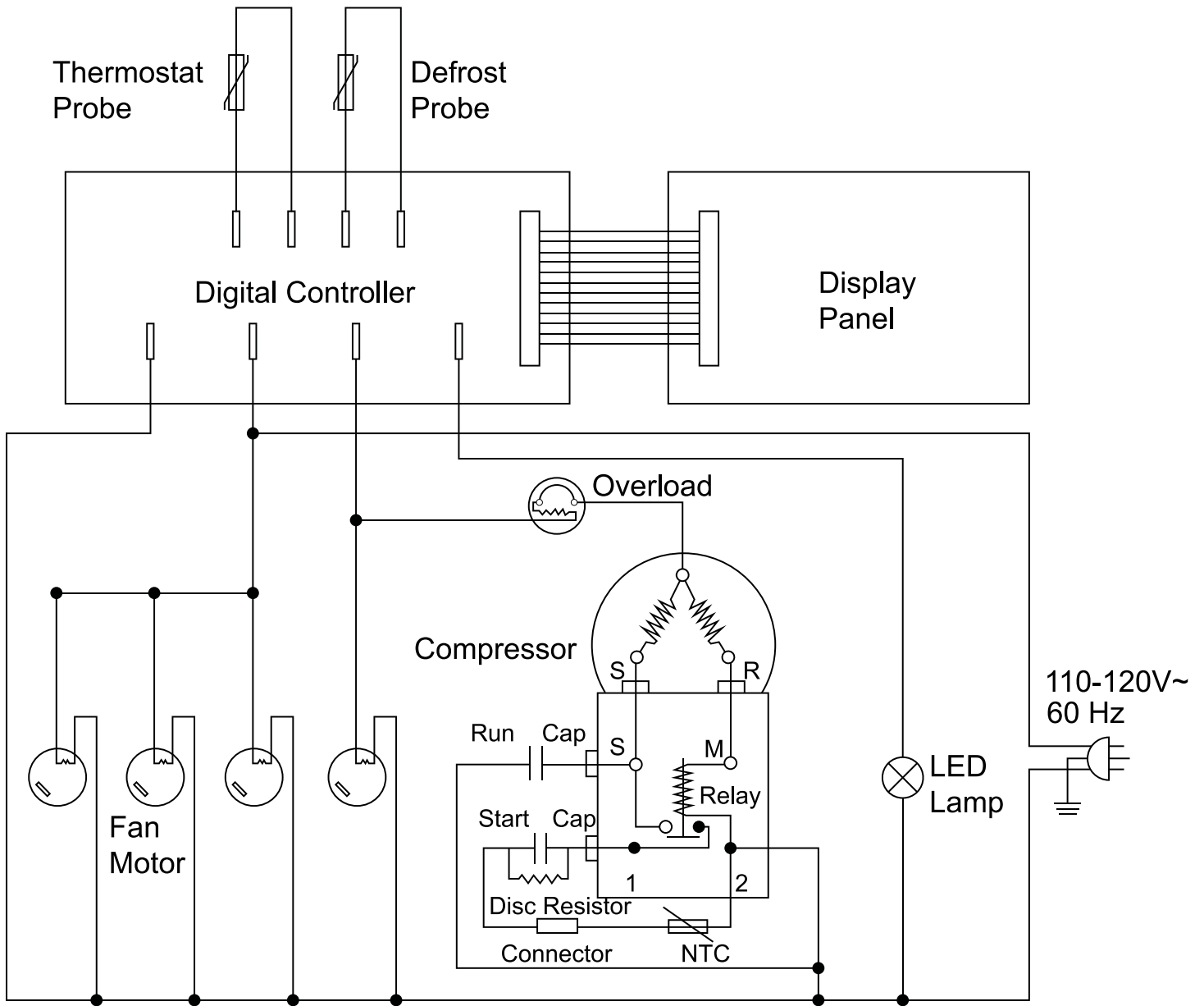





# Warranty Registration

Thank you for purchasing an Omcan product. To register your warranty for this product, complete the information below, tear off the card at the perforation and then send to the address specified below. You can also register online by visiting:

Merci d'avoir acheté un produit Omcan. Pour enregistrer votre garantie pour ce produit, complétez les informations ci-dessous, détachez la carte au niveau de la perforation, puis l'envoyer à l'adresse spécifiée ci-dessous. Vous pouvez également vous inscrire en ligne en visitant:

Gracias por comprar un producto Omcan usted. Para registrar su garantía para este producto, complete la información a continuación, cortar la tarjeta en la perforación y luego enviarlo a la dirección indicada a continuación. También puede registrarse en línea en:

<https://omcan.com/warranty-registration/>

For mailing in Canada

Pour postale au Canada

Por correo en Canadá

For mailing in the US

Pour diffusion aux États-Unis

Por correo en los EE.UU.

**OMCAN**

PRODUCT WARRANTY REGISTRATION

3115 Pepper Mill Court,

Mississauga, Ontario

Canada, L5L 4X5

**OMCAN**

PRODUCT WARRANTY REGISTRATION

4450 Witmer Industrial Estates, Unit 4,

Niagara Falls, New York

USA, 14305

*or email to: [service@omcan.com](mailto:service@omcan.com)*



Purchaser's Information

Name: \_\_\_\_\_

Address: \_\_\_\_\_

City: \_\_\_\_\_ Province or State: \_\_\_\_\_ Postal or Zip: \_\_\_\_\_

Country: \_\_\_\_\_

Dealer from which Purchased: \_\_\_\_\_

Dealer City: \_\_\_\_\_ Dealer Province or State: \_\_\_\_\_

Invoice: \_\_\_\_\_

Company Name: \_\_\_\_\_

Telephone: \_\_\_\_\_

Email Address: \_\_\_\_\_

Type of Company:

Restaurant  Bakery  Deli

Butcher  Supermarket  Caterer

Institution (*specify*): \_\_\_\_\_

Other (*specify*): \_\_\_\_\_

Model Name: \_\_\_\_\_ Model Number: \_\_\_\_\_

Serial Number: \_\_\_\_\_

Machine Description: \_\_\_\_\_

Date of Purchase (MM/DD/YYYY): \_\_\_\_\_

Date of Installation (MM/DD/YYYY): \_\_\_\_\_

Would you like to extend the warranty?  Yes  No

**Thank you for choosing Omcan | Merci d'avoir choisi Omcan | Gracias por elegir Omcan**



Since 1951 Omcan has grown to become a leading distributor of equipment and supplies to the North American food service industry. Our success over these many years can be attributed to our commitment to strengthen and develop new and existing relationships with our valued customers and manufacturers. Today with partners in North America, Europe, Asia and South America, we continually work to improve and grow the company. We strive to offer customers exceptional value through our qualified local sales and service representatives who provide convenient access to over 6,500 globally sourced products.

---

Depuis 1951 Omcan a grandi pour devenir un des “leaders” de la distribution des équipements et matériel pour l’industrie des services alimentaires en Amérique du Nord. Notre succès au cours de ces nombreuses années peut être attribué à notre engagement à renforcer et à développer de nouvelles et existantes relations avec nos clients et les fabricants de valeur. Aujourd’hui avec des partenaires en Amérique du Nord, Europe, Asie et Amérique du Sud, nous travaillons continuellement à améliorer et développer l’entreprise. Nous nous efforçons d’offrir à nos clients une valeur exceptionnelle grâce à nos ventes locales qualifiées et des représentants de service qui offrent un accès facile à plus de 6500 produits provenant du monde entier.

---

Desde 1951 Omcan ha crecido hasta convertirse en un líder en la distribución de equipos y suministros de alimentos en América del Norte industria de servicios. Nuestro éxito en estos años se puede atribuir a nuestro compromiso de fortalecer y desarrollar nuevas relaciones existentes con nuestros valiosos clientes y fabricantes. Hoy con socios de América del Norte, Europa, Asia y América del Sur, que trabajan continuamente para mejorar y crecer la empresa. Nos esforzamos por ofrecer a nuestros clientes valor excepcional a través de nuestro local de ventas y representantes de los servicios que proporcionan un fácil acceso a más de 6,500 productos con origen a nivel mundial.

