



Blenders

Models BL-BR-0015, 0025

Items 37969, 31502

Instruction Manual



Revised - 07/25/2024



Toll Free: 1-800-465-0234
Fax: 905-607-0234
Email: service@omcan.com
www.omcan.com



Table of Contents

Model BL-BR-0015 / Model BL-BR-0025

Section	Page
General Information -----	3 - 4
Safety and Warranty -----	4 - 6
Technical Specifications -----	7
Installation -----	8 - 10
Operation -----	10 - 11
Maintenance -----	11 - 13
Parts Breakdown -----	14 - 17
Electrical Schematics -----	18
Warranty Registration -----	19



General Information

Omcan Manufacturing and Distributing Company Inc., Food Machinery of America, Inc. dba Omcan and Omcan Inc. are not responsible for any harm or injury caused due to any person's improper or negligent use of this equipment. The product shall only be operated by someone over the age of 18, of sound mind, and not under the influence of any drugs or alcohol, who has been trained in the correct operation of this machine, and is wearing authorized, proper safety clothing. Any modification to the machine voids any warranty, and may cause harm to individuals using the machine or in the vicinity of the machine while in operation.

CHECK PACKAGE UPON ARRIVAL

Upon receipt of an Omcan shipment please inspect for external damage. If no damage is evident on the external packaging, open carton to ensure all ordered items are within the box, and there is no concealed damage to the machine. If the package has suffered rough handling, bumps or damage (visible or concealed), please note it on the bill of lading before accepting the delivery and contact Omcan within 24 hours, so we may initiate a claim with the carrier. A detailed report on the extent of the damage caused to the machine must be filled out within three days, from the delivery date shown in the shipping documents. Omcan has no recourse for damaged products that were shipped collect or third party.

Before operating any equipment, always read and familiarize yourself with all operation and safety instructions.

Omcan would like to thank you for purchasing this machine. It's of the utmost importance to save these instructions for future reference. Also save the original box and packaging for shipping the equipment if servicing or returning of the machine is required.

Omcan Fabrication et distribution Compagnie Limitée et Food Machinery d'Amérique, dba Omcan et Omcan Inc. ne sont pas responsables de tout dommage ou blessure causé du fait que toute personne ait utilisé cet équipement de façon irrégulière. Le produit ne doit être exploité que par quelqu'un de plus de 18 ans, sain d'esprit, et pas sous l'influence d'une drogue ou d'alcool, qui a été formé pour utiliser cette machine correctement, et est vêtu de vêtements de sécurité appropriés. Toute modification de la machine annule toute garantie, et peut causer un préjudice à des personnes utilisant la machine ou des personnes à proximité de la machine pendant son fonctionnement.

VÉRIFIEZ LE COLIS DÈS RÉCEPTION

Dès réception d'une expédition d'Omcan veuillez inspecter pour dommages externes. Si aucun dommage n'est visible sur l'emballage externe, ouvrez le carton afin de s'assurer que tous les éléments commandés sont dans la boîte, et il n'y a aucun dommage dissimulé à la machine. Si le colis n'a subi aucune mauvaises manipulations, de bosses ou de dommages (visible ou cachée), notez-le sur le bond de livraison avant d'accepter la livraison et contactez Omcan dans les 24 heures qui suivent, pour que nous puissions engager une réclamation auprès du transporteur. Un rapport détaillé sur l'étendue des dommages causés à la machine doit être rempli dans un délai de trois jours, à compter de la date de livraison indiquée dans les documents d'expédition. Omcan n'a aucun droit de recours pour les produits endommagés qui ont été expédiés ou cueillis par un tiers transporteur.

Avant d'utiliser n'importe quel équipement, toujours lire et vous familiariser avec toutes les opérations et les

General Information

consignes de sécurité.

Omcan voudrais vous remercier d'avoir choisi cette machine. Il est primordial de conserver ces instructions pour une référence ultérieure. Également conservez la boîte originale et l'emballage pour l'expédition de l'équipement si l'entretien ou le retour de la machine est nécessaire.

Omcan Empresa De Fabricacion Y Distribucion Inc. Y Maquinaria De Alimentos De America, Inc. dba Omcan y Omcan Inc. no son responsables de ningun daño o perjuicio causado por cualquier persona inadecuada o el uso descuidado de este equipo. El producto solo podra ser operado por una persona mayor de 18 años, en su sano juicio y no bajo alguna influencia de droga o alcohol, y que este ha sido entrenado en el correcto funcionamiento de esta máquina, y ésta usando ropa apropiada y autorizada. Cualquier modificación a la máquina anula la garantía y puede causar daños a las personas usando la máquina mientras esta en el funcionamiento.

REVISE EL PAQUETE A SU LLEGADA

Tras la recepcion de un envio Omcan favor inspeccionar daños externos. Si no hay daños evidentes en el empaque exterior, Habra el carton para asegurarse que todos los articulos solicitados estén dentro de la caja y no encuentre daños ocultos en la máquina. Si el paquete ha sufrido un manejo de poco cuidado, golpes o daños (visible o oculto) por favor anote en la factura antes de aceptar la entrega y contacte Omcan dentro de las 24 horas, de modo que podamos iniciar una reclamación con la compañía. Un informe detallado sobre los daños causados a la máquina debe ser llenado en el plazo de tres días, desde la fecha de entrega que se muestra en los documentos de envío. Omcan no tiene ningun recurso por productos dañados que se enviaron a recoger por terceros.

Antes de utilizar cualquier equipo, siempre lea y familiarizarse con todas las instrucciones de funcionamiento y seguridad.

Omcan le gustaría darle las gracias por la compra de esta máquina. Es de la mayor importancia para salvar estas instrucciones para futuras consultas. Además, guarda la caja original y el embalaje para el envío del equipo si servicio técnico o devolución de la máquina que se requiere.

Safety and Warranty

The high performance tilting blenders are simple to use and clean. However, for your safety read the following instructions in order to avoid accidents:

1. Always unplug the machine when cleaning, servicing or when any other maintenance operation is needed.
2. Never use tools that do not belong to the machine during operation.
3. Never spray water on the machine.
4. Do not operate the machine while wearing wet clothes or wet shoes.
5. Before operating the machine, make sure it is properly grounded.
6. When washing inside of the cup N°02 (Pic. 01) ensure power is off and unit is unplugged. Be careful with

Safety and Warranty

the blade as it has sharp edges.



GENERAL SAFETY PRACTICES

The following safety instructions are addressed to both the operator of the machine as well as the person in charge of maintenance. The user shall operate the machine only after being well acquainted with the safety procedures described in the present manual. **READ THIS MANUAL THOROUGHLY.**

BASIC OPERATION PRACTICES

Dangerous parts

Some parts of the electric devices are connected to high voltage points. These parts when touched may cause severe electrical shocks or can even be **FATAL**. Never touch commands such as buttons, switches and knobs with wet hands, wet clothes and/or shoes. By not following these instructions, operators could be exposed to severe electrical shocks or even to a **FATAL** situation.

Warnings

The operator has to be well familiar with the position of **ON/OFF** switch to make sure the switch is easily accessible when necessary. Before any kind of maintenance, physically remove plug from the socket. Provide space for a comfortable operation thus avoiding accidents. Water or oil spilled on the floor will cause additional hazards. Make sure the floor is clean and dry. Before giving any manual command (switch, buttons, turn keys or lever) be sure the command is the correct one. Check this manual for further details if necessary. Never use a manual command (switch, buttons, lever) unadvisedly. If any work is to be made by two or more people, coordination signs will have to be given for each operation step. Every step of the operation shall be taken only if the sign has been made and responded.

Advice

In case of power shortage, immediately turn the machine **OFF**. Use recommended or equivalent lubricants, oils or greases. Avoid mechanical shocks as they may cause failures or malfunction. Avoid penetration of water, dirt or dust into mechanical or electrical components of the machine. **DO NOT MODIFY** original characteristics of the machine. **DO NOT REMOVE, TEAR OFF or MACULATE ANY SAFETY or IDENTIFICATION LABELS** stuck on the machine. If any label has been removed or is no longer legible, contact your nearest dealer for replacement.

Safety and Warranty

SAFETY PROCEDURES AND NOTES BEFORE SWITCHING MACHINE ON

IMPORTANT: carefully read **ALL INSTRUCTIONS** of this manual before turning the machine **ON**. Be sure to be familiar with the instructions and that you have understood all information contained in this manual. If you have any questions contact your supervisor or your nearest dealer.

Danger

An electric cable or electric wire with damaged jacket or bad insulation could cause electrical shocks as well as electrical leak. Before use, unplug and check conditions of all wires and cables.

Advice

Be sure **ALL INSTRUCTIONS** in this manual have been thoroughly understood. Every function and operational procedure have to be very clear to the operator. Contact your nearest dealer for further questions. Any manual command (switch, button or lever) shall be given only after being sure it is the correct one.

Precautions

The electric cable has to be compatible with the power required by the machine. Cables touching the floor or close to the machine need to be protected against short circuits.

RESIDENTIAL USERS: vendor assumes no liability for parts or labor coverage for component failure or other damages resulting from installation in non-commercial or residential applications. The right is reserved to deny shipment for residential usage; if this occurs, you will be notified as soon as possible.

1 YEAR PARTS AND LABOUR BENCH WARRANTY

Within the warranty period, contact Omcan Inc. at 1-800-465-0234 to schedule a drop off to either an Omcan authorized service depot in the area, or to an Omcan Service warehouse to repair the equipment.

Unauthorized maintenance will void the warranty. Warranty covers electrical and part failures, not improper use.

Please see <https://omcan.com/disclaimer> for complete info.

WARNING:

The packaging components (cardboard, polyethylene, and others) are classified as normal solid urban waste and can therefore be disposed of without difficulty.

In any case, for suitable recycling, we suggest disposing of the products separately (differentiated waste) according to the current norms.

DO NOT DISCARD ANY PACKAGING MATERIALS IN THE ENVIRONMENT!

Technical Specifications

MAIN COMPONENTS

All components are made with carefully selected materials, in accordance with Omcan experience and standard testing procedures.

- 01 - Lid.
- 02 - Cup.
- 03 - On/off switch.
- 04 - Stand.
- 05 - Motor.
- 06 - Lock pedal.

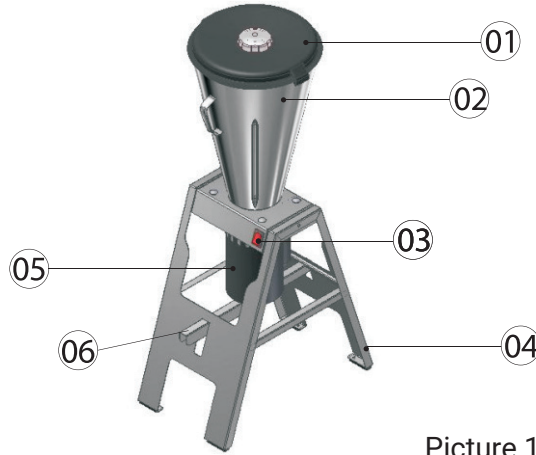

Picture 1

Item Number	37969	31502
Model	BL-BR-0015	BL-BR-0025
Cup Capacity	15 L / 15.9 QT	25 L / 26.4 QT
Power	1.5 HP / 1,120 W	
Rotation	3500	
Electrical	110-120V / 60Hz / 1	
Cup Material	Stainless Steel	
Base Material	Carbon Steel	
Weight	41.9 lbs. / 19 kgs.	45.2 lbs. / 20.5 kgs.
Packaging Weight	65 lbs. / 29.5 kgs.	70.3 lbs. / 31.9 kgs.
Dimensions	20.7" x 14" x 44" 525 x 355 x 1118mm	20.7" x 15.3" x 46.4" 525 x 388 x 1178mm
Packaging Dimensions	23" x 16" x 45" / 584 x 406 x 1143mm	23" x 16" x 50" / 584 x 406 x 1270mm

Installation

PADDLE AND SPRING ASSEMBLY

1. Fit the spring in the holes located at the stand.

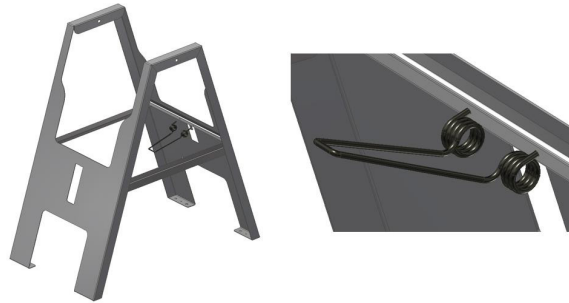

2. Place the paddle in the frontal cut of the stand.



3. Press the paddle's back portion down (as indicated in the red arrow below), tensioning the spring. During this process, it is important to hold the spring in its place, fitted to the holes in the stand, to avoid any misplacement.

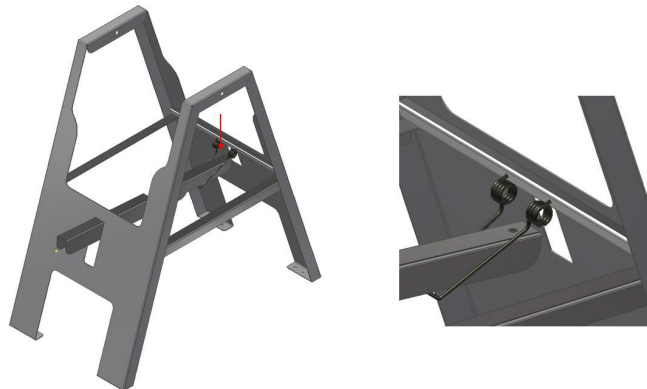

Installation

4. With the spring tensioned, push the paddle back until it fits in the rear cut of the stand.



5. Fit the paddle's hole to the stand pin and shown below.

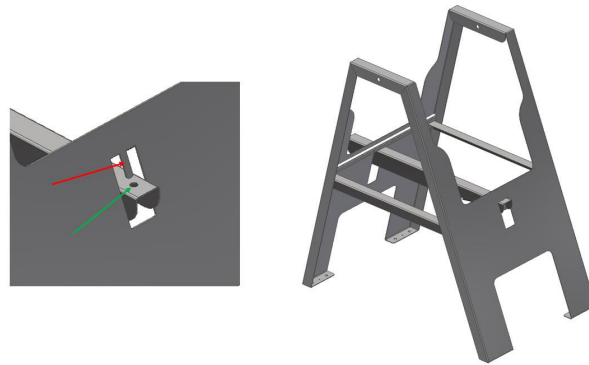

6. Check to see if the paddle is working correctly.



The high performance tilting blenders were developed to be used in 110V. Grounding is mandatory.

Installation

PRE OPERATION

First of all check if the blender is firm on its position. Check if motor (N°01) is perfectly fitted on the lock pedal (N°02) as shown on Picture 2.

01 - Motor.
02 - Pedal lock.

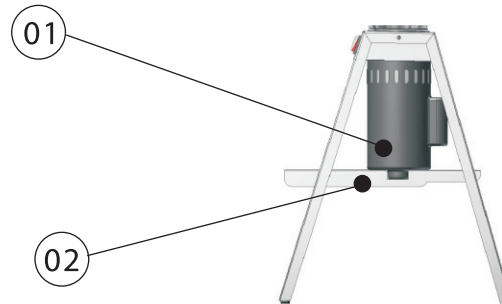

Picture 2

IMPORTANT: before doing any maintenance to the machine switch it OFF and unplug it.

Operation

STARTING

The blender is activated by turning the on/off switch N°03 (Pic.01) to **ON** position.

OPERATING PROCEDURES

The high performance tilting blender works at high speed (approximately 3.500 rpm, 50Hz). To feed it proceed as follows:

1. Remove the lid N°01 (Pic.01).
2. Put product inside the cup N°02 (Pic.01) with the machine switched **OFF**.
3. Place the lid N°01 (Pic.01) back on top of the cup and switch the machine **ON**.

NOTE: due to turbulence generated when machine is ON do not turn it ON without the lid N°01 (Pic.01). The processing time depends on the kind of product.

IMPORTANT: NEVER SWITCH THE MACHINE ON WITHOUT PRODUCT IN IT BECAUSE IT WILL CAUSE IRREPARABLE DAMAGES.

IMPORTANT: it is not recommended to blend products without the addition of any liquid, otherwise it will overheat and damage the cup seal.

DISCHARGING PROCEDURES

To discharge processed product from blender models proceed as follows:

1. Turn machine OFF.
2. Remove lid N°01 (Pic. 01).
3. Press lock pedal N°06 (Pic. 01) down.
4. Tilt cup N°02 (Pic. 01) holding its handle and discharge processed product as needed.

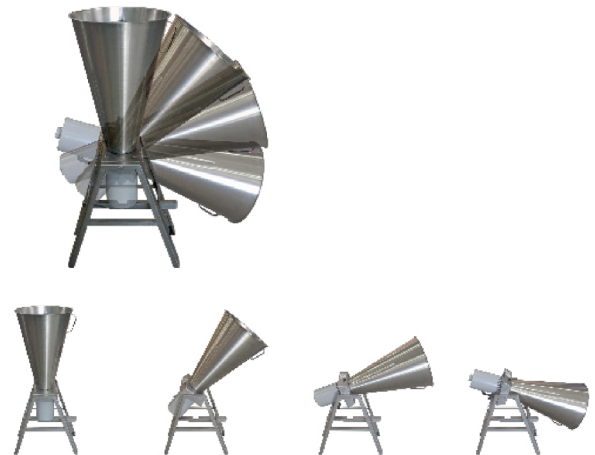

Maintenance

CLEANING

The new blenders cup has stamped ribs that facilitate cleaning. Wash the lid N°01 and the cup N°02 (Pic. 01) with water and neutral soap. Wipe up the other parts with a damp cloth.

IMPORTANT: never do cleaning with machine plugged in. Always unplug machine before cleaning. When washing inside the cup be careful with the blade.

MAINTENANCE

Danger

Any maintenance with the machine in working situation is dangerous. **TURN IT OFF BY PULLING THE PLUG OFF THE SOCKET DURING MAINTENANCE.**

IMPORTANT: always unplug the machine when emergency cases arise.

Advice

Electrical or mechanical maintenance must be done by qualified personal for such operation. Person in charge has to be sure that the machine is under **TOTAL SAFETY** conditions when working.

ROUTINE INSPECTION - UNPLUG MACHINE

Advice

When checking the tension of the belts or chains, **DO NOT** introduce your fingers between the belts and the

Maintenance

pulleys and nor between the chain and the gears.

Precautions

Check if motors and sliding or turning parts of the machine produce abnormal noises. Check the tension of the belts and chains and replace the set when belt or chain show signs of being worn out. When checking tensions of belts or chain **DO NOT** introduce your fingers between belts and pulleys, nor between the chains and gears. Check protections and safety devices to make sure they are working properly.

OPERATION

Advice

Be sure your hair is not loose in order to avoid getting caught by turning parts which could lead to a serious accident. Tie your hair up and/or cover your head with a scarf. The operation performed by untrained personnel shall be forbidden. Never touch turning parts with your hands or in any other way. **NEVER** operate machine without all original safety devices under perfect conditions.

CAUTIONS WITH STAINLESS STEEL:

The stainless steel may present rust signs, which **ARE ALWAYS CAUSED BY EXTERNAL AGENTS**, especially when the cleaning or sanitization is not constant and appropriate. The stainless steel resistance towards corrosion is mainly due to the presence of chrome, which in contact with oxygen allows the formation of a very thin protective coat. This protective coat is formed through the whole surface of the steel, blocking the action of external corrosive agents. When the protective coat is broken, the corrosion process begins, being possible to avoid it by means of constant and adequate cleaning. Cleaning must always be done immediately after using the equipment. For such end, use water, neutral soap or detergent, and clean the equipment with a soft cloth or a nylon sponge. Then rinse it with plain running water, and dry immediately with a soft cloth, this way avoiding humidity on surfaces and especially on gaps. The rinsing and drying processes are extremely important to prevent stains and corrosion from arising.

IMPORTANT: acid solutions, salty solutions, disinfectants and some sterilizing solutions (hypochlorites, tetravalent ammonia salts, iodine compounds, nitric acid and others), must be AVOIDED, once it cannot remain for long in contact with the stainless steel.

These substances attack the stainless steel due to the **CHLORINE** on its composition, causing corrosion spots (pitting). Even detergents used in domestic cleaning must not remain in contact with the stainless steel longer than necessary, being mandatory to remove it with plain water and then dry the surface completely.

Use of abrasives:

Sponges or steel wool and carbon steel brushes, besides scratching the surface and compromising the stainless steel protection, leave particles that rust and react contaminating the stainless steel. That is why such products must not be used for cleaning and sanitization. Scrapings made with sharp instruments or similar must also be avoided.

Main substances that cause stainless steel corrosion:

Dust, grease, acid solutions such as vinegar, fruit juices, etc., saltern solutions (brine), blood, detergents

(except for the neutral ones), common steel particles, residue of sponges or common steel wool, and also other abrasives.

ANALYSIS AND PROBLEMS SOLVING

Problems, causes and solutions

The high performance tilting blenders were designed to operate with the need of minimum maintenance but the natural wearing caused by long use of the equipment may occasionally cause some malfunctions. If such problem occurs with your blender refer to table below in which the most common situations are listed with recommended solutions.

Problems	Causes	Solutions
The machine does not turn on.	Lack of power.	Check if machine is plugged in and if there is power in the power supply source.
	Problem in the electric circuit of the machine.	Call technical assistance.
Cup is leaking.	Damaged seal.	Call technical assistance.

Parts Breakdown

Model BL-BR-0015 37969

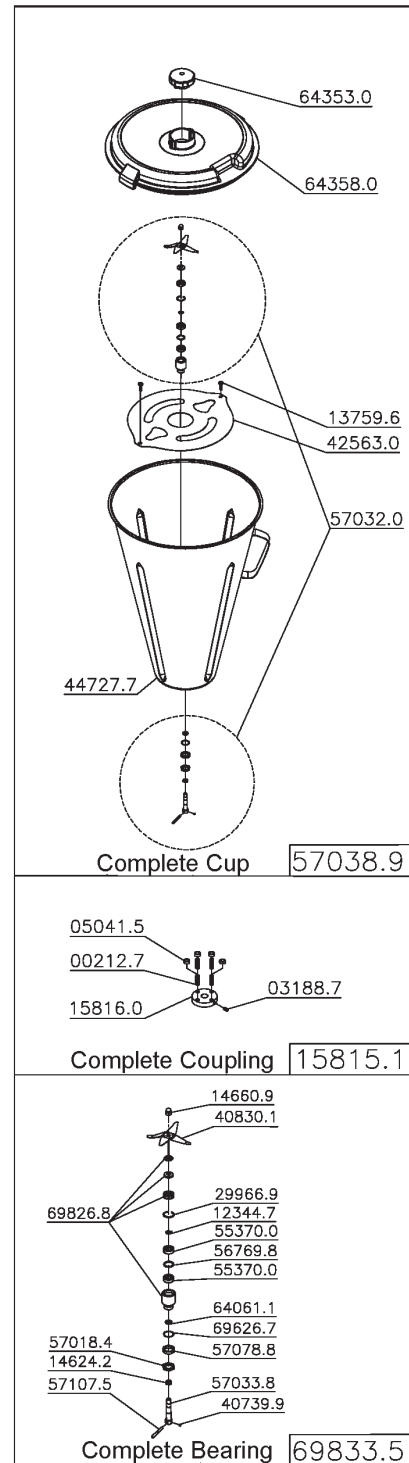
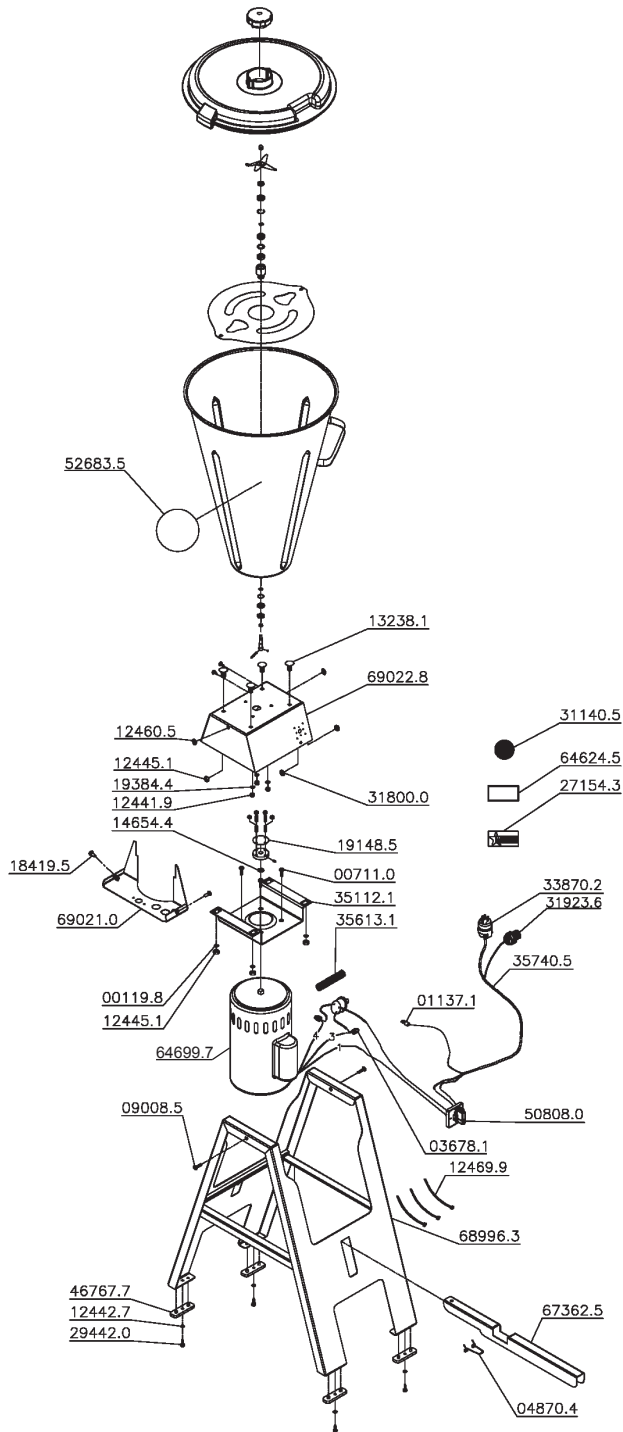

Parts Breakdown

Model BL-BR-0015 37969

Item No.	Description	Position	Item No.	Description	Position	Item No.	Description	Position
30258	Washer L 5/16 ZB for 37969	00119.8	38222	Nut 10x1.25 for 37969	15816.0	AE682	Rolam.6001 DDU NSK/TK Di.12xDe.28xL.8 for 37969	55370.0
38217	Elastic Pin 6x22 for 37969	00212.7	AE674	PFS M6x16 Din 7985 Stainless for 37969	18419.5	AE684	Distancing Washer for 37969	56769.8
30324	Six Sided Screw UNC 3/8x7/8 RTZB for 37969	00711.0	79041	Deflector for 37969	19148.5	AE685	PCA Sex Low M24x1.5 Stainless Steel for 37969	57018.4
AE670	Term. Eyelet for 37969	01137.1	38341	Washer 1/4x5/8x1.2mm Stainless Steel for 37969	19384.4	AE686	Complete Cutting/Bearing Assembly for 37969	57032.0
27695	Allen Screw M6x8 for 37969	03188.7	27720	Omcans Logo (Machines) for 37969	27154.3	AE687	Central Axle for 37969	57033.8
27696	Nylon Cover CN 4478 for 37969	03678.1	38302	PFS Auto Broc 4.2x13 ZB for 37969	29442.0	AE688	Full Cup for 37969	57038.9
24023	The Spring Rocker for 37969	04870.4	AE676	Ring 28x1.2 Din 472 Fosf. for 37969	29966.9	AE689	Distancer for 37969	57078.8
38220	Distanc. Washer for 37969	05041.5	67038	Grounded Wire Label for 37969	31140.5	AE690	Guide Pin 6x50 Din 7 M6 w/Down for 37969	57107.5
38297	PFS M8x40 Din 933 ZB for 37969	09008.5	67039	Nut M4 Din 985 Stainless Steel for 37969	31800.0	AE694	Backring Ring for 37969	64061.1
AE672	Earring Ring 12x1 Din 471 for 37969	12344.7	27726	Cord Holder PG13.5 LC+P/9 for 37969	31923.6	AE695	MB Less Overhead for 37969	64353.0
16418	Nut N M6 Din 985 Stainless Steel for 37969	12441.9	AE678	American Plug Cert.20A 115V (4A255) for 37969	33870.2	AE696	Cover 15 (FE006-111) for 37969	64358.0
16419	Washer L.A6 4 125 Inox for 37969	12442.7	38288	Motor Support (Grey) for 37969	35112.1	AE698	Danger I / F for 37969	64624.5
16421	Screw Nut M8 934 Inox for 37969	12445.1	38289	Plastic Conduit for 37969	35613.1	AE700	Motor 1.5CV 60Hz W (14547104) for 37969	64699.7
16423	Washer L.A8.4 Stainless Steel for 37969	12460.5	AE679	CB.3x3.3mm2 SJX2M Certif. for 37969	35740.5	AP009	Pedal (Grey) for 37969	67362.5
30045	Bracer K22-LM(T-80I) for 37969	12469.9	38482	Screw M5x10 Din 84 Inox for 37969	40739.9	AC966	Stand Grey for 37969	68996.3
38086	Screw M8x16 Din 933 Stainless Steel for 37969	13238.1	27845	Blade CS Helice Type MB for 37969	40830.1	AE702	CS Closing Cabinet for 37969	69021.0
67029	Screw M6x10 Din 933 Stainless Steel for 37969	13759.6	AC969	Cup Safety Device for 37969	42563.0	AE703	CS Tilting Support (Gray) for 37969	69022.8
38274	V'Ring 16 5x10 5x5 5 for 37969	14624.2	AC970	Cup 15 Liters for 37969	44727.7	AP010	Oring Ring 30.31x25.07x2.62mm for 37969	69626.7
38295	Fiber Washer 20x13x0.7 for 37969	14654.4	38300	Rectangular Foot (Mol 483753) for 37969	46767.7	AP011	Bearing + Rings (Scraper/Seal) + R for 37969	69826.8
38312	Nut 10x1.25 for 37969	14660.9	AN193	Rotary Disconnect Switch MSW 20 P2 for 37969	50808.0	AE686	Complete Cutting/Bearing Assembly for 37969	69833.5
38308	Complete Clutch for 37969	15815.1	AE681	Etiqu.E / I Cup MB 145mm 15 for 37969	52683.5			

Parts Breakdown

Model BL-BR-0025 31502

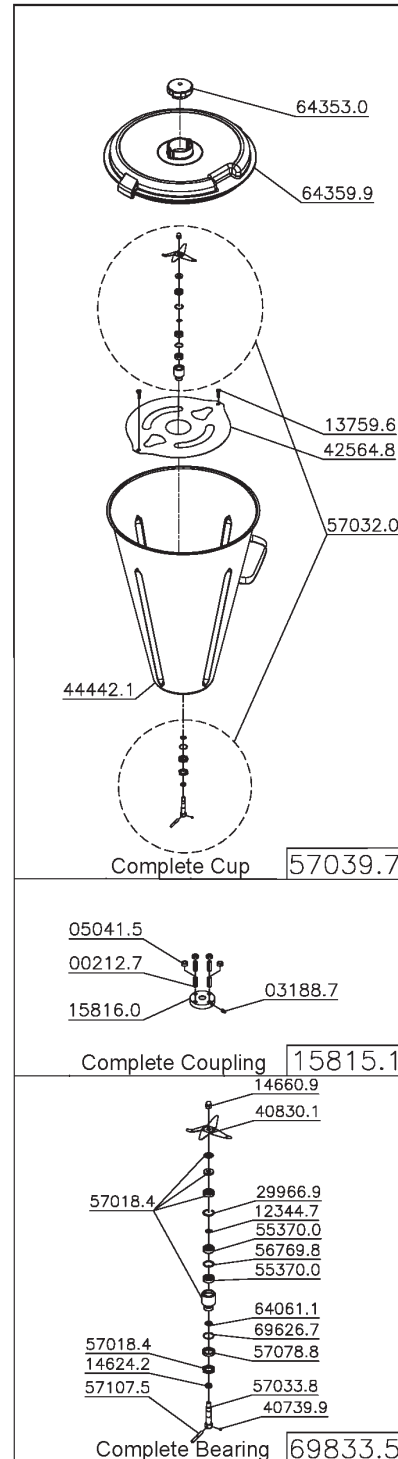
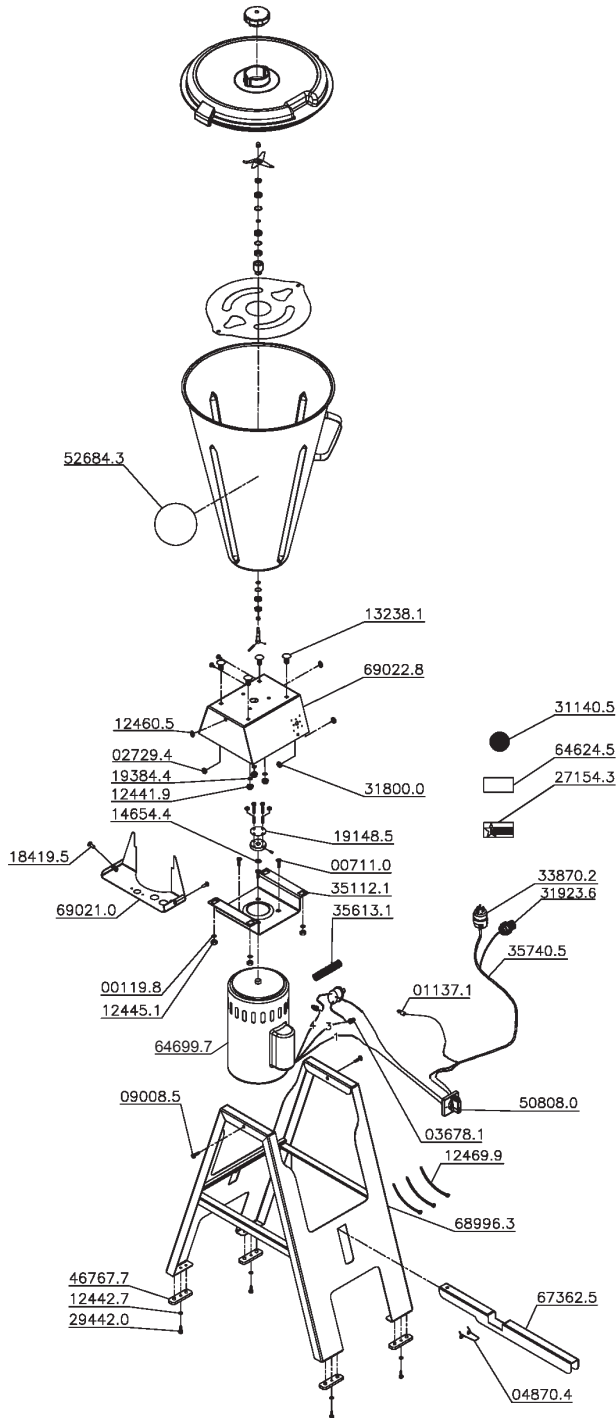

Parts Breakdown

Model BL-BR-0025 31502

Item No.	Description	Position	Item No.	Description	Position	Item No.	Description	Position
30258	Washer L 5/16 ZB for 31502	00119.8	38308	Complete Clutch for 31502	15815.1	AP012	Label E/I Cup MB 145mm 25 for 31502	52684.3
38217	Elastic Pin 6x22 for 31502	00212.7	38222	Nut 10x1.25 for 31502	15816.0	AE682	Rolam.6001 DDU NSK/TK Di.12xDe.28xL.8 for 31502	55370.0
30324	Six Sided Screw UNC 3/8x7/8 RTZB for 31502	00711.0	AE674	PFS M6x16 Din 7985 Stainless for 31502	18419.5	AE684	Distancing Washer for 31502	56769.8
AE670	Term. Eyelet for 31502	01137.1	79041	Deflector for 31502	19148.5	AE685	PCA Sex Low M24x1.5 Stainless Steel for 31502	57018.4
38557	Screw Nut Din 934 ZB for 31502	02729.4	38341	Washer 1/4x5/8x1.2mm Stainless Steel for 31502	19384.4	AE686	Complete Cutting/Bearing Assembly for 31502	57032.0
27695	Allen Screw M6x8 for 31502	03188.7	27720	Omcan Logo (Machines) for 31502	27154.3	AE687	Central Axle for 31502	57033.8
27696	Nylon Cover CN 4478 for 31502	03678.1	38302	PFS Auto Broc 4.2x13 ZB for 31502	29442.0	AE705	Full Cup for 31502	57039.7
24023	The Spring Rocker for 31502	04870.4	AE676	Ring 28x1.2 Din 472 Fosf. for 31502	29966.9	AE689	Distancer for 31502	57078.8
38220	Distanc. Washer for 31502	05041.5	67038	Grounded Wire Label for 31502	31140.5	AE690	Guide Pin 6x50 Din 7 M6 w/Down for 31502	57107.5
38297	PFS M8x40 Din 933 ZB for 31502	09008.5	67039	Nut M4 Din 985 Stainless Steel for 31502	31800.0	AE694	Backring Ring for 31502	64061.1
AE672	Earring Ring 12x1 Din 471 for 31502	12344.7	27726	Cord Holder PG13.5 LC+P/9 for 31502	31923.6	AE695	MB Less Overhead for 31502	64353.0
16418	Nut N M6 Din 985 Stainless Steel for 31502	12441.9	AE678	American Plug Cert.20A 115V (4A255) for 31502	33870.2	AE708	Cover 25 (FE006-112) for 31502	64359.9
16419	Washer L.A6 4 125 Inox for 31502	12442.7	38288	Motor Support (Grey) for 31502	35112.1	AE698	Danger I / F for 31502	64624.5
16421	Screw Nut M8 934 Inox for 31502	12445.1	38289	Plastic Conduit for 31502	35613.1	AE700	Motor 1.5CV 60Hz W (14547104) for 31502	64699.7
16423	Washer L.A8.4 Stainless Steel for 31502	12460.5	AE679	CB.3x3.3mm2 SJX2M Certif. for 31502	35740.5	AP009	Pedal (Grey) for 31502	67362.5
30045	Bracer K22-LM(T-80) for 31502	12469.9	38482	Screw M5x10 Din 84 Inox for 31502	40739.9	AC966	Stand Grey for 31502	68996.3
38086	Screw M8x16 Din 933 Stainless Steel for 31502	13238.1	27845	Blade CS Helice Type MB for 31502	40830.1	AE702	CS Closing Cabinet for 31502	69021.0
67029	Screw M6x10 Din 933 Stainless Steel for 31502	13759.6	AC967	Cup Safety Device for 31502	42564.8	AE703	CS Tilting Support (Gray) for 31502	69022.8
38274	V Ring 16 5x10 5x5 5 for 31502	14624.2	AC968	CS Cup for 31502	44442.1	AP010	Oring Ring 30.31x25.07x2.62mm for 31502	69626.7
38295	Fiber Washer 20x13x0.7 for 31502	14654.4	38300	Rectangular Foot (Mol 483753) for 31502	46767.7	AE686	Complete Cutting/Bearing Assembly for 31502	69833.5
38312	Nut 10x1.25 for 31502	14660.9	AN193	Rotary Disconnect Switch MSW 20 P2 for 31502	50808.0			

Electrical Schematics

Model BL-BR-0015 37969

Model BL-BR-0025 31502

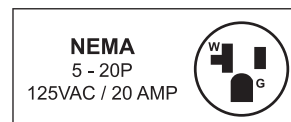
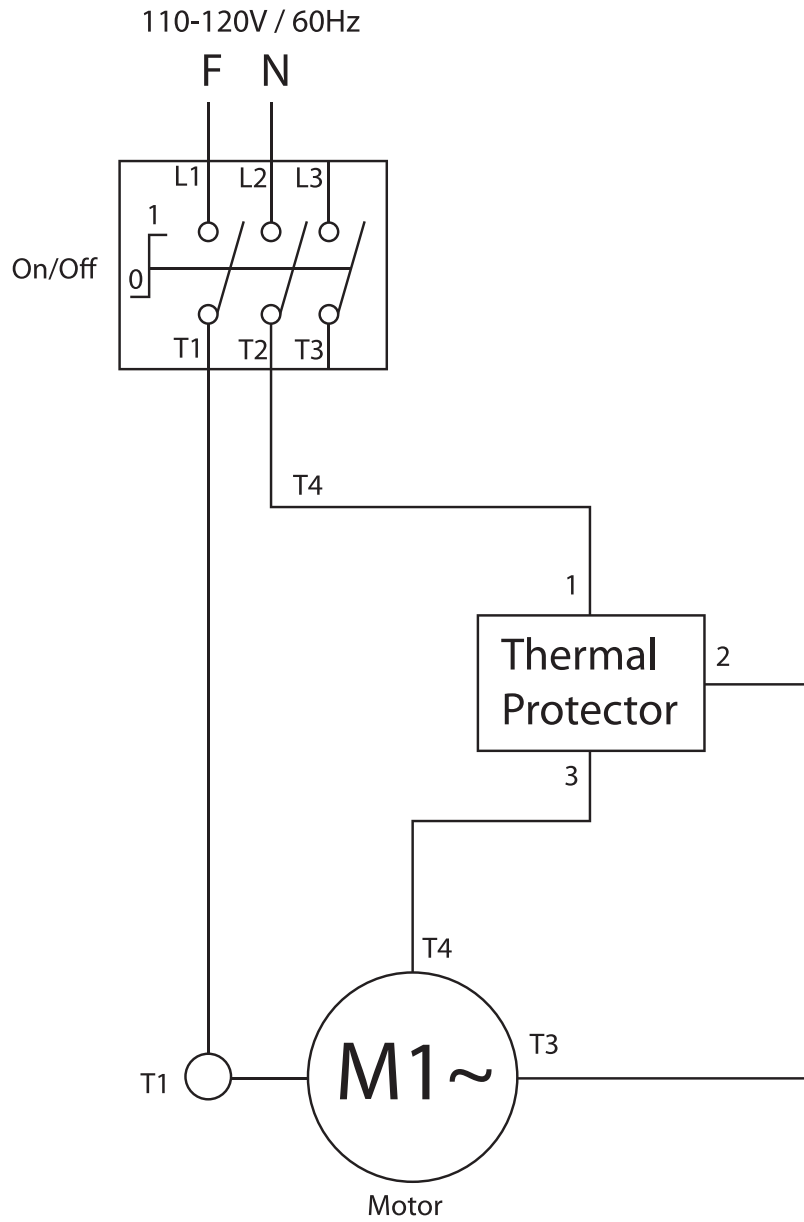



Warranty Registration

Thank you for purchasing an Omcan product. To register your warranty for this product, complete the information below, tear off the card at the perforation and then send to the address specified below. You can also register online by visiting:

Merci d'avoir acheté un produit Omcan. Pour enregistrer votre garantie pour ce produit, complétez les informations ci-dessous, détachez la carte au niveau de la perforation, puis l'envoyer à l'adresse spécifiée ci-dessous. Vous pouvez également vous inscrire en ligne en visitant:

Gracias por comprar un producto Omcan usted. Para registrar su garantía para este producto, complete la información a continuación, cortar la tarjeta en la perforación y luego enviarlo a la dirección indicada a continuación. También puede registrarse en línea en:

<https://omcan.com/warranty-registration/>

For mailing in Canada

Pour postale au Canada

Por correo en Canadá

For mailing in the US

Pour diffusion aux États-Unis

Por correo en los EE.UU.

OMCAN

PRODUCT WARRANTY REGISTRATION

3115 Pepper Mill Court,
Mississauga, Ontario
Canada, L5L 4X5

OMCAN

PRODUCT WARRANTY REGISTRATION

4450 Witmer Industrial Estates, Unit 4,
Niagara Falls, New York
USA, 14305

or email to: service@omcan.com



Purchaser's Information

Name: _____

Address: _____

City: _____ Province or State: _____ Postal or Zip: _____

Country: _____

Dealer from which Purchased: _____

Dealer City: _____ Dealer Province or State: _____

Invoice: _____

Model Name: _____ Model Number: _____

Machine Description: _____

Date of Purchase (MM/DD/YYYY): _____

Would you like to extend the warranty? Yes No

Company Name: _____

Telephone: _____

Email Address: _____

Type of Company:

Restaurant Bakery Deli

Butcher Supermarket Caterer

Institution (specify): _____

Other (specify): _____

Serial Number: _____

Date of Installation (MM/DD/YYYY): _____

Thank you for choosing Omcan | Merci d'avoir choisi Omcan | Gracias por elegir Omcan



Since 1951 Omcan has grown to become a leading distributor of equipment and supplies to the North American food service industry. Our success over these many years can be attributed to our commitment to strengthen and develop new and existing relationships with our valued customers and manufacturers. Today with partners in North America, Europe, Asia and South America, we continually work to improve and grow the company. We strive to offer customers exceptional value through our qualified local sales and service representatives who provide convenient access to over 6,500 globally sourced products.

Depuis 1951 Omcan a grandi pour devenir un des "leaders" de la distribution des équipements et matériel pour l'industrie des services alimentaires en Amérique du Nord. Notre succès au cours de ces nombreuses années peut être attribué à notre engagement à renforcer et à développer de nouvelles et existantes relations avec nos clients et les fabricants de valeur. Aujourd'hui avec des partenaires en Amérique du Nord, Europe, Asie et Amérique du Sud, nous travaillons continuellement à améliorer et développer l'entreprise. Nous nous efforçons d'offrir à nos clients une valeur exceptionnelle grâce à nos ventes locales qualifiées et des représentants de service qui offrent un accès facile à plus de 6500 produits provenant du monde entier.

Desde 1951 Omcan ha crecido hasta convertirse en un líder en la distribución de equipos y suministros de alimentos en América del Norte industria de servicios. Nuestro éxito en estos años se puede atribuir a nuestro compromiso de fortalecer y desarrollar nuevas relaciones existentes con nuestros valiosos clientes y fabricantes. Hoy con socios de América del Norte, Europa, Asia y América del Sur, que trabajan continuamente para mejorar y crecer la empresa. Nos esforzamos por ofrecer a nuestros clientes valor excepcional a través de nuestro local de ventas y representantes de los servicios que proporcionan un fácil acceso a más de 6,500 productos con origen a nivel mundial.

