



REFRIGERATION

SERVING THE FOOD INDUSTRY SINCE 1951

53-INCH 2-DOOR SLIDING GLASS COOLER

Item: 50032 Model: RE-CN-0045-HC



THE PERFECT SOLUTION TO EXHIBIT COLD MERCHANDISE

Omcan's 53-inch 2-door sliding glass cooler is perfect for your products, with the outside material made from painted steel. Its crystal clear, self closing door is perfect to see the products inside. It also features automatic defrosting and high density polyurethane insulation. Energy Certified.



WARRANTY

2 YEARS PARTS & LABOR
5 YEARS ONLY ON COMPRESSOR

NEMA
5 - 15
125 VAC / 15 AMP



SHIPPED ON PALLET



Authorized Dealer

REFRIGERATION

53-INCH 2-DOOR SLIDING GLASS COOLER 50032



TECHNICAL SPECIFICATION

ITEM NUMBER	50032
MODEL	RE-CN-0045-HC
DESCRIPTION	2-Door Sliding Glass Cooler
TEMPERATURE RANGE	0°C - 5°C / 33°F - 41°F
MAX AMBIENT TEMP RATING	90°F
POWER	0.25+
PHASE	1
ELECTRICAL	110V/60Hz/1Ph
AMPS	4.3
REFRIGERANT	R290
COOLING SYSTEM	Ventilated
NUMBER OF DOORS	2
NUMBER OF SHELVES	8
NET VOLUME	45 cu.ft. / 1270 liters
SHELF CAPACITY	90 lbs. / 41 kg.
EXTERIOR DIMENSIONS (WDH)	53.25" x 32" x 83.8" 1353 x 813 x 2129 mm
INTERIOR DIMENSIONS (WDH)	50" x 28.25" x 62" 1270 x 718 x 1575 mm
PACKAGING DIMENSIONS	56.3" x 33.46" x 84" 1430 x 850 x 2134 mm
NET WEIGHT	441 lbs. / 200 kg.
GROSS WEIGHT	496 lbs. / 225 kg.



Features:

- Outside material: Painted steel
- Self-closing doors
- Plastic coated steel shelves with shelf tag holder
- Automatic defrosting
- Polyurethane insulation
- Removable door gasket
- Removable installation board for easy maintenance
- Shelf Capacity: 90 lbs. / 41 kg.
- Temperature range: 0°C - 5°C / 33°F - 41°F

TECHNICAL DRAWING AND DIMENSIONS

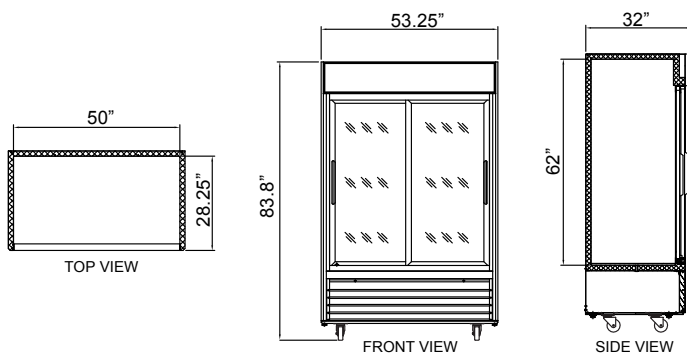

NEMA
5 - 15
125 VAC / 15 AMP



OMCAN INC.

Telephone: 1-800-465-0234

Fax: (905) 607-0234

Email: sales@omcan.com

Website: www.omcan.com



Follow us to keep up to date with the latest news and offers



2017E&OE